

*The best way
to cut & groove*

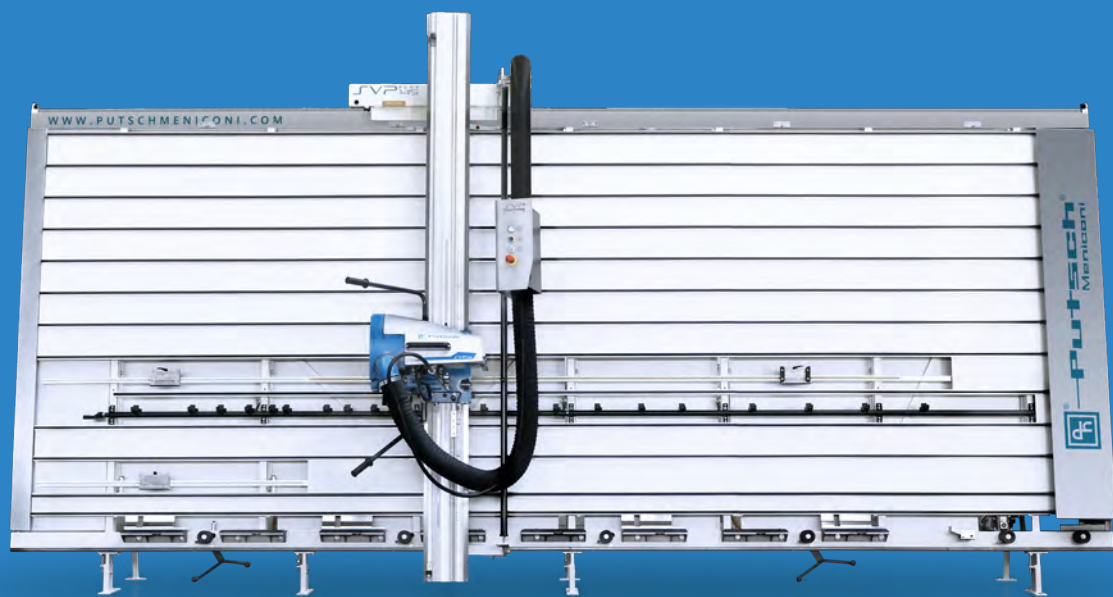

SVP
S E R I E S
100% MADE IN ITALY

TECHNOLOGY | RELIABILITY | INNOVATION
TECNOLOGÍA | CONFIABILIDAD | INNOVACIÓN



Our identity has its roots in the purest and most genuine Made in Italy; an identity made of respect for the artisanal Italian tradition, acquired skills in more than sixty years of activity, care and growth for our precious workers, which allow us to achieve new and important goals, year after year. This is us, with care and passion that always have been a certainty for our customers. This is us, Putsch Meniconi. And we are proud to show it to you in this new catalog

Nuestra identidad tiene sus raíces en el más puro y genuino Made in Italy; una identidad hecha de respeto por la tradición italiana artesanal, las habilidades adquiridas en más de sesenta años de actividad, cuidado y crecimiento para nuestros preciados colaboradores, lo que nos permite alcanzar nuevas e importantes metas, año tras año.

Somos nosotros, con cuidado y pasión, que siempre han sido sin duda una certeza para nuestros clientes. Estos somos nosotros, Putsch Meniconi. Y estamos orgullosos de mostrárselo en este nuevo catálogo.

Team Putsch Meniconi





 
100% MADE IN ITALY



Putsch Meniconi a company immersed in the heart of Tuscany. A story long over 60 years.

Putsch Meniconi is a Tuscan company, made in Italy, established in Poggibonsi in 1956, where more than 50 high-profile resources, are currently successfully employed.

Putsch Meniconi sells worldwide its CNC machines, vertical panel saws, horizontal panel saws, and a first class customer assistance as well, in a world market that include more than 75 countries.

Putsch Meniconi is committed every day to find new materials and innovative technologies to create new panel saws and CNC machines, both in line with the new production speed requirements, and to save space and time.

In fact, every year Putsch Meniconi invests part of its turnover, in supporting research activities and innovation of its vertical panel saws, horizontal panel saws and CNC machines.

Thanks to the collaboration with the best technical institutes, Putsch Meniconi works with the best professionals, with an excellent preparation in mechanics and electronics.

The production and assembly workers safely manage the whole production process of vertical, horizontal panel saws and CNC machines, which take place in an area of 9000 square meters, in Poggibonsi in the heart of Tuscany



Putsch Meniconi es una empresa inmersa en el corazón de la Toscana. Una historia larga más de 60 años.

Putsch Meniconi es una empresa toscana, Made in Italy, establecida en Poggibonsi en 1956, donde actualmente se emplean con éxito más de 50 recursos de alto perfil.

Putsch Meniconi vende en todo el mundo sus seccionadoras verticales, seccionadoras horizontales, centros de mecanizado CNC y también un servicio post-venta de primera clase, en un mercado mundial que incluye más de 75 países.

Putsch Meniconi se compromete todos los días a encontrar nuevos materiales y tecnologías innovadoras para crear nuevas seccionadoras verticales, horizontales y centros de mecanizado verticales CNC, tanto en línea con los nuevos requisitos de velocidad de producción, como para ahorrar espacio y tiempo.

De hecho, todos los años Putsch Meniconi invierte parte de su volumen de ventas en actividades de investigación e innovación de sus seccionadoras verticales, seccionadoras horizontales y centros de mecanizado verticales CNC.

Gracias a la colaboración con los mejores institutos técnicos, Putsch Meniconi trabaja con los mejores profesionales, con una excelente preparación en mecánica y electrónica

Los trabajadores de producción y montaje gestionan de forma segura todo el proceso de producción de las seccionadoras verticales, horizontales, y máquinas CNC, que tienen lugar en una área de 9000 metros cuadrados en Poggibonsi en el corazón de la Toscana.



Putsch® Group

Putsch Group is an international brand, made up of some of the best high-tech companies in the world. The head office of this company holding is located in Hagen, Germany.

Putsch group is well established and esteemed all over the world for its ability to provide its customers with customized cutting materials machines, totally safe, respectful of international regulations, and a personalized continuous assistance.

Putsch Meniconi provides products and services with an high quality standard, thanks to the continuous staff training and updating. The company policy of Putsch Group is totally customer oriented, i.e. aimed at favoring the reduction of business costs, the increase in productivity and, consequently, the turnover's growth of its customers.

La empresa Putsch Meniconi S.p.A. es parte integrante del grupo alemán, con sede en Hagen, Putsch® Gmbh & Co que permiten a esta holding internacional llevar una red de venta extendida en todo el mundo y garantizar un pronto Servicio Global a todos sus clientes.

Este grupo es exitoso y apreciado en todo el mundo, ya que siempre ofrece a sus clientes máquinas para cortar materiales que cumplen completamente con las normas de seguridad.

Los productos y servicios de Putsch Meniconi son de alta calidad gracias a la formación continua de todos los trabajadores. La política de la compañía Putsch Group está totalmente orientada al cliente y está destinada a favorecer la reducción de los costos de la empresa, el crecimiento de la productividad y, en consecuencia, el crecimiento de la facturación de sus clientes.



24 hours a day, 7 days a week guaranteed Assistance everywhere in the World

Servicio post-venta garantizado las 24 horas del día y los 7 días de la semana



The Best customized solutions proposed by Putsch Meniconi

Las Mejores Soluciones Personalizadas propuestas por Putsch Meniconi



Guaranteed World Coverage by the Best Panel Saws Dealers.

Cobertura mundial garantizada por los mejores distribuidores de seccionadoras.



The purchase of Putsch Meniconi machines guarantees its value over time

La compra de máquinas Putsch Meniconi garantiza su valor en el tiempo.

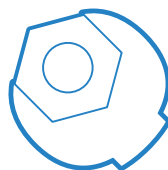

Custom installation for each customer

Instalación personalizada de todas las máquinas para cada cliente.



Satisfy every customer's needs in Italy and in the world every day

Satisfacer las necesidades de cada cliente en todo el mundo.

WOOD / MADERA



Chipboard
Conglomerados

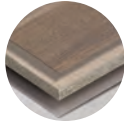

Melamine panels
Melaminicos



Solid Wood
Madera Maciza

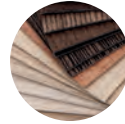

Laminated
Laminados



Plywood
Contrachapado

COMPOSITES / COMPOSITES



Panels HPL
Paneles HPL



Sandwich
Sandwich

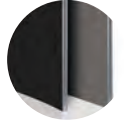

Reynobond®
Reynobond®

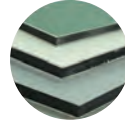

Etabond®
Etabond®

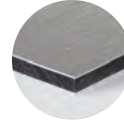

Dibond®
Dibond®

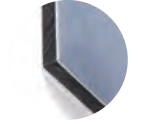

Alupanel®
Alupanel®

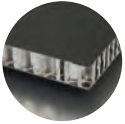

Alucore®
Alucore®

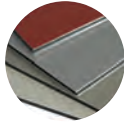

Alucobond®
Alucobond®

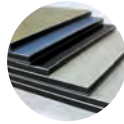

Panels ACM-ACP
Paneles ACM-ACP

PLASTICS / PLASTICOS



Plastics Materials
Materiales plasticos



Polypropylene
Polipropileno

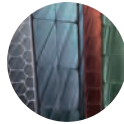

Polycarbonate
Policarbonato



Plexiglass
Plexiglass



Forex
Forex

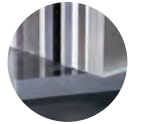

Methacrylate
Metacrilato

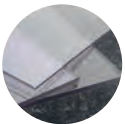

Makrolon®
Makrolon®

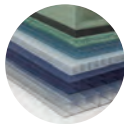

Lexan®
Lexan®



Plastic Laminates
Laminados Plasticos



PVC
PVC

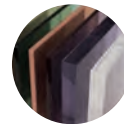

Acrylic
Acrílico

SPECIAL / ESPECIALES

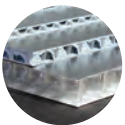

Honeycomb
Paneles de nidos de abeja

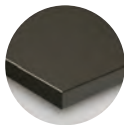

Trespa®
Trespa®



Fiberglass
Fibra de vidrio



Polyurethane
Poliuretano

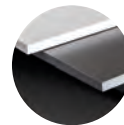

Corian®
Corian®



Plasterboard
Pladur



Insulated
Paneles Aislantes

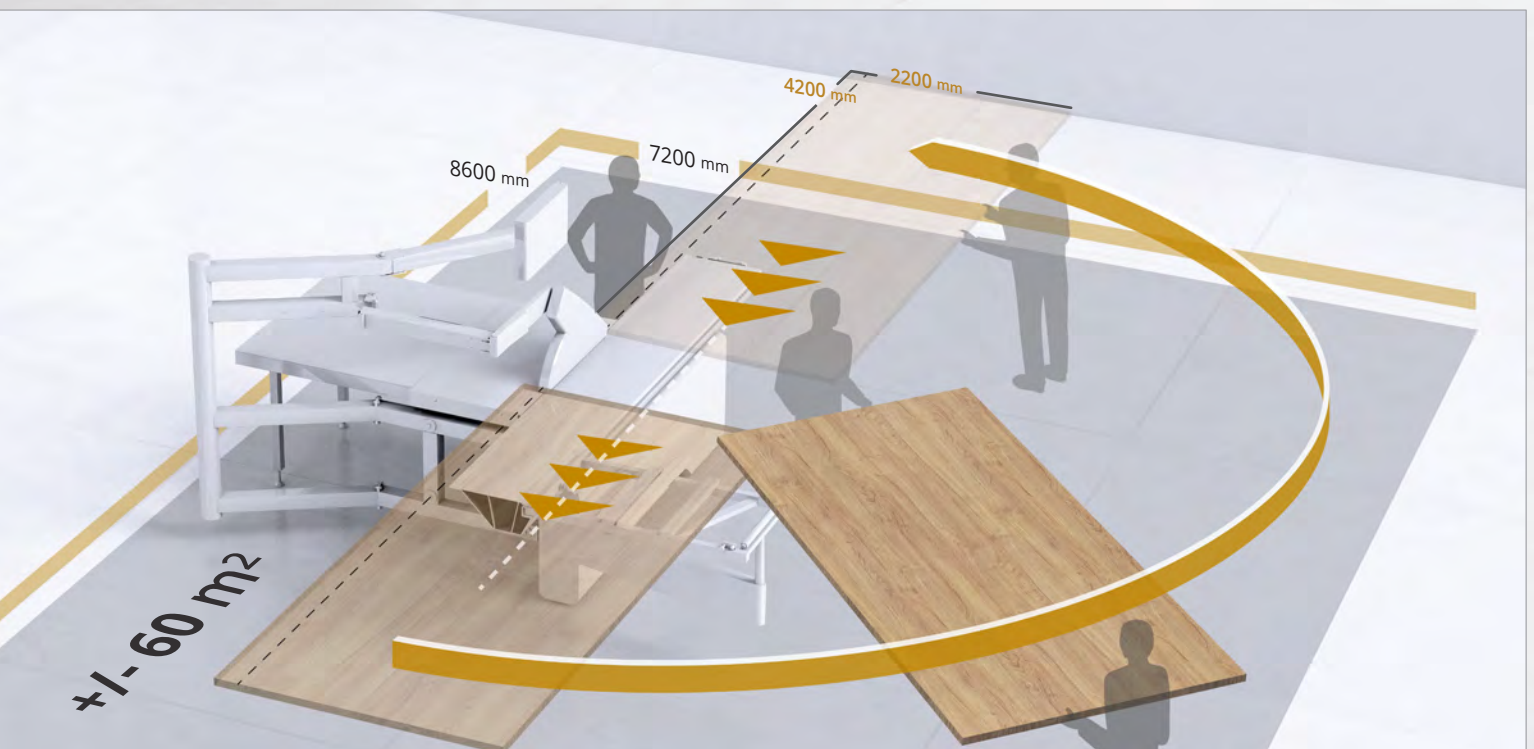
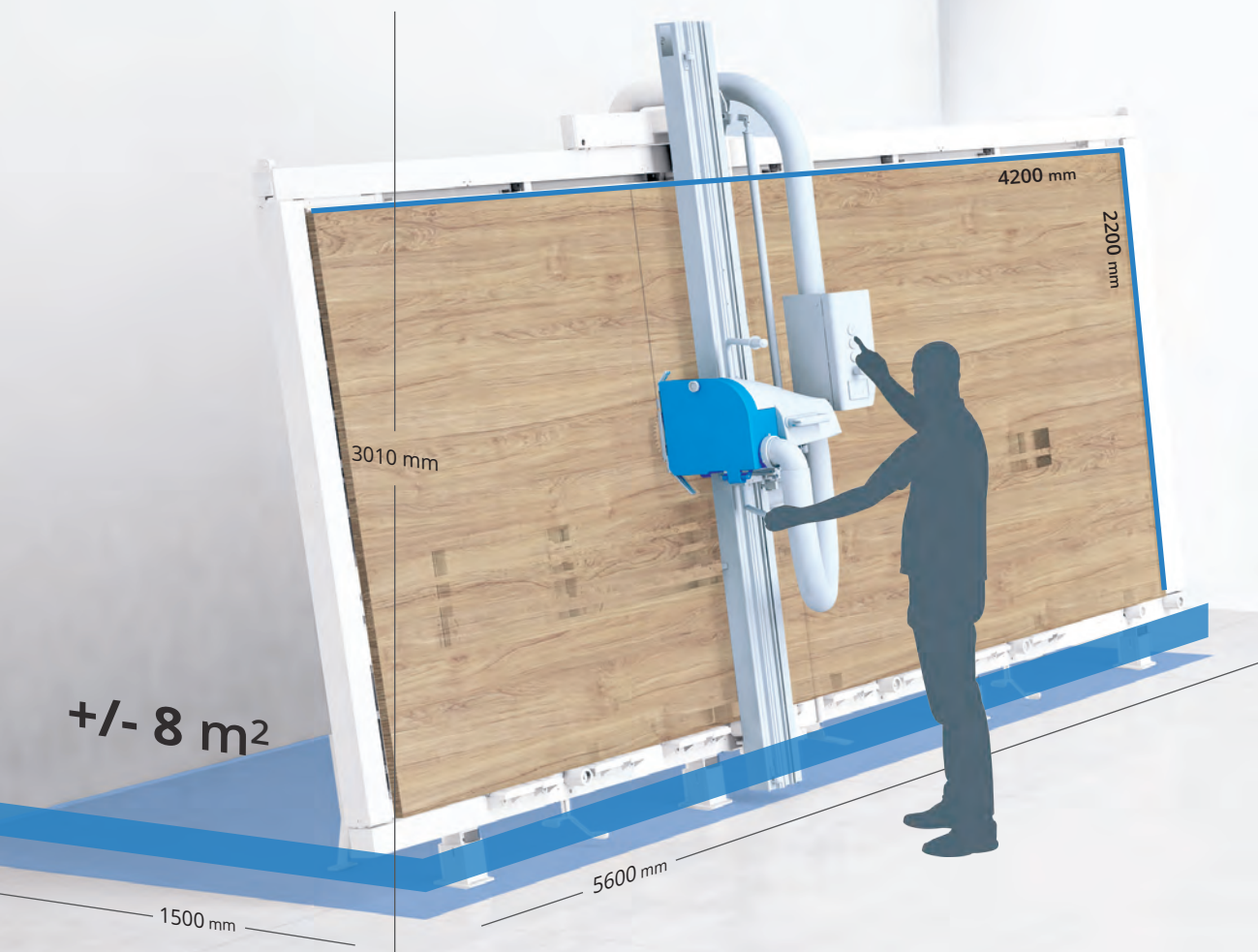

The comparison with a sliding table saw shows how this machine requires at least 2 people to manage the cutting of large panels and how the area required increases considerably during the work.

La comparación con una escuadradora clásica muestra cómo esta máquina requiere por lo menos 2 personas para manejar el corte de grandes paneles y que el volumen de espacio aumenta considerablemente durante el trabajo.



MAXIMUM SAFETY AND RELIABILITY
MÁXIMA SEGURIDAD Y CONFIABILIDAD



HIGH PERFORMANCES
ALTO RENDIMIENTO



PROFITABLE AND LASTING INVESTMENT
INVERSIÓN RENTABLE Y DURADERA



SPACE SAVER
DIMENSIONES REDUCIDAS

Why choose a Putsch Meniconi Vertical Panel Saw

Reduced dimensions

Unlike traditional sliding table, vertical panel saw have small sizes and occupy minimal production areas, because it uses heights as a work area. Thanks to a special layout it only occupies one wall, easily adapting to small rooms, to meet the most diversified customer needs.

Maximum safety and reliability

Vertical panel saw is a safer tool than sliding table, because its covered saw blade always avoids direct contact between operator, blade carriage and materials in every phase of process. In the automatic version, after positioning the panel and setting dimensions, the operator can simply supervise the cutting phase, further increasing the level of safety and optimizing working times.

Profitable and lasting investment

The excellent quality / price ratio makes vertical panel saw a profitable investment even for companies with small staff. Just an operator is able to complete the job, whereas a sliding table would require at least two to move the panels. Vertical panel saw is a long lasting and versatile product, suitable for cutting different materials, and highly customizable thanks to the available optionals.

High Performances

Vertical panel saw achieves results difficult to match with traditional machines. Saw heads run on linear guides, so it guarantees highest accuracy and precision, rapidity of execution and ease of use even during the most complex phases. If assembled by our authorized technicians and in optimal environmental conditions, Putsch Meniconi vertical panel saw reaches a tolerance of only 0.1mm per meter. Finally, not having to move the panel by hand, you avoid scratches and imperfections that could compromise the final result.

Porqué elegir una seccionadora vertical Putsch Meniconi

Dimensiones reducidas

A diferencia de la escuadradora clásica, la seccionadora vertical tiene dimensiones más pequeñas y ocupa un mínimo espacio interno porque utiliza la altura como área de trabajo. Gracias a su diseño, solo ocupa una pared, y se adapta fácilmente al lugar de trabajo de pequeña escala para satisfacer las necesidades más diversas de los clientes.

Máxima seguridad y confiabilidad

La seccionadora vertical es una máquina mas segura que la máquina escuadradora, ya que su protector de la sierra siempre evita el contacto directo entre el operador, el carro hojas y los materiales en cada fase del proceso. En la versión automática, después la colocación del panel y la configuración de las dimensiones, el operador puede simplemente supervisar la fase de corte, aumentando el nivel de seguridad y optimizando los tiempos de trabajo.

Inversión rentable y duradera

La excelente relación calidad / precio hace que la seccionadora vertical sea una inversión ventajosa incluso para empresas con poco personal. Solo un operador puede ejecutar el trabajo, mientras una máquina escuadradora requeriría al menos dos personas para mover los paneles. La seccionadora vertical es un producto duradero y versátiles, adecuado para cortar diferentes materiales y altamente personalizable gracias a la posibilidad de agregar numerosas opciones.

Alto rendimiento

La seccionadora vertical logra resultados difíciles de igualar con las escuadradoras clásicas. La estabilidad del panel está asegurada por soportes de bases de aluminio cubiertos de polizeno que aseguran firmeza en el corte y garantizando la máxima precisión. Además garantiza una rapidez de ejecución y facilidad de uso incluso la máxima seguridad durante las operaciones de corte. La seccionadora vertical armada por nuestros técnicos autorizados y en óptimas condiciones ambientales, garantiza una tolerancia de solo 0,1 mm por metro. La ventaja de utilizar una seccionadora vertical es también el hecho que se evita el desplazamiento del tablero para los cortes verticales y horizontales que podría dañar los tableros mismos y afectar el acabado.

Vertical panel saw series 133 baby / Seccionadoras verticales serie 133 baby



SVP 133 Baby **12**

SVP 133 Baby S **12**



Vertical panel saw series 133 / Seccionadoras verticales serie 133



SVP 133 S **14**

SVP 133 Plus **16**

SVP 133 Automatic **18**



Vertical panel saw series 145 / Seccionadoras verticales serie 145



SVP 145 S **22**

SVP 145 Plus **24**

SVP 145 Automatic **26**

SVP 145 Plus Alu **28**



Vertical panel saw series 320 / Seccionadoras verticales serie 320



SVP 320 Manual	32
SVP 320 Automatic	34

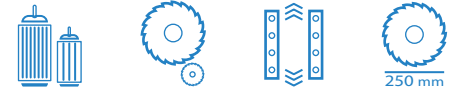

Vertical panel saw series 420 / Seccionadoras verticales serie 420



SVP 420 Manual	36
SVP 420 Automatic	38
SVP 420 Automatic touch	40
SVP 420 CS H	42
SVP 420 Automatic CS H	44

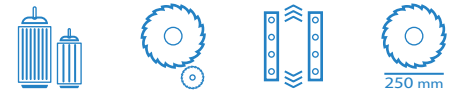

Vertical panel saw series 950 / Seccionadoras verticales serie 950



SVP 950 Manual	46
SVP 950 Automatic	48



Vertical panel saw series 980 / Seccionadoras verticales serie 980

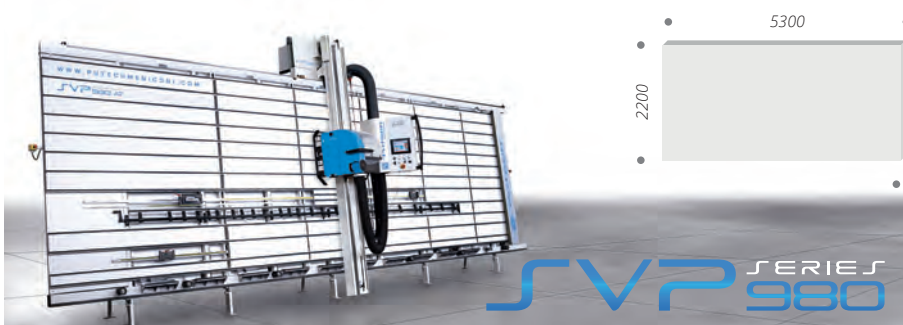

SVP 980 AT	50
------------	-----------



SVP BABY 133 S
100% MADE IN ITALY

SVP BABY 133
100% MADE IN ITALY

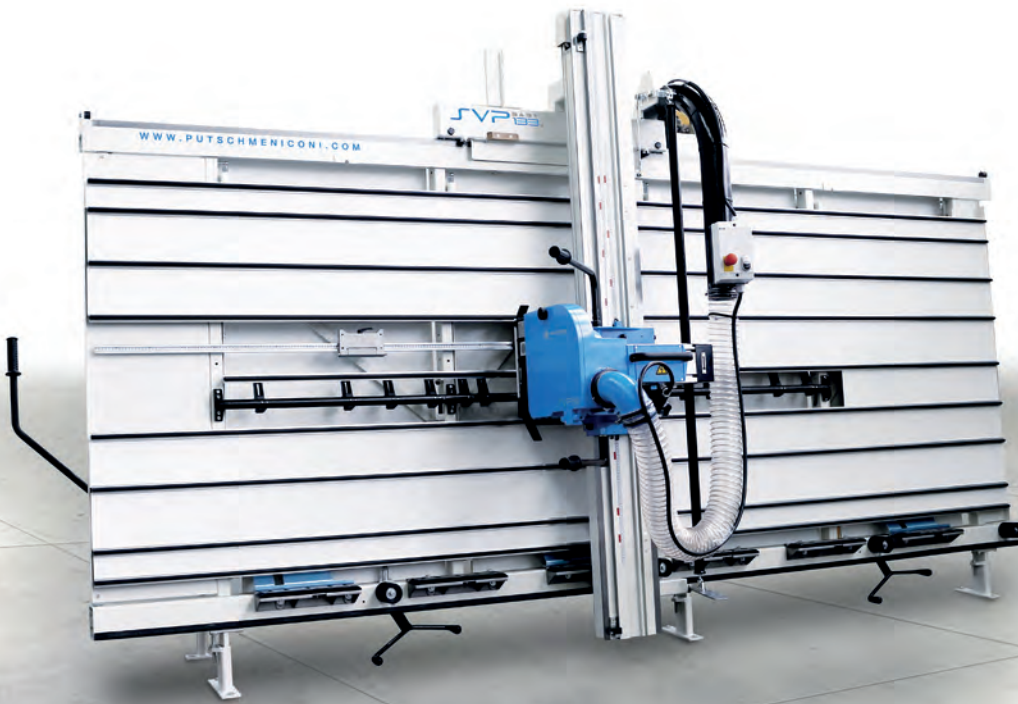

Electrowelded frame
Bastidor electrosoldado



Aluminum lower supports coated in polyzene with retractable rollers
Soportes inferiores de aluminio recubiertos de polizeno con ruedas retráctiles



Manual shifting frame (Baby S)
Parrilla móvil manual (Baby S)



Automatic shifting frame
Parrilla móvil automática



Manual cut execution
Ejecución corte manual



These are vertical panel saws responding to all cutting requirements and offering the best value for money. Thanks to a wide range of accessories, these machines guarantee performances that are typical of higher-category equipments and increase profitability.

Son las seccionadoras verticales ideales para cualquier necesidad de corte, con la mejor relación calidad/precio del mercado. Se trata de máquinas versátiles que, gracias a una amplia gama de accesorios, pueden ofrecer las prestaciones típicas de una máquina de categoría superior y aumentar la rentabilidad.

OVERALL SIZES AND CUTTING CAPACITY / DIMENSIONES Y CAPACIDADES DE CORTE

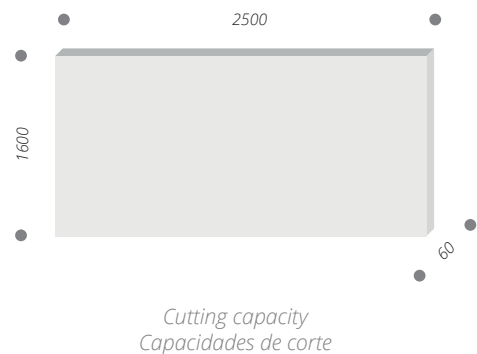
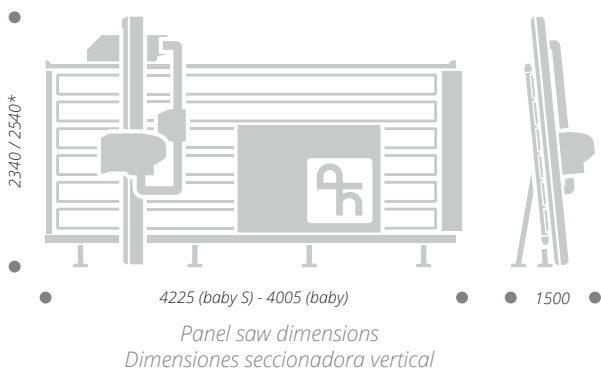

CUTTING MATERIALS / CORTE MATERIALES

SVP 133 BABY S is designed for wood - special - plastics materials cutting.

SVP 133 BABY S está diseñada para cortar madera - materiales especiales - plasticos

* with scoring blade
* con hojas incisoras

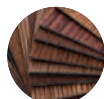

Wood Panels
Paneles de madera



Special Materials
Materiales especiales



Trespa®



Insulated panels
Paneles aislantes



Corian®



Plasterboard
Pladur

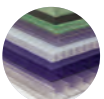

Plastic materials
Plasticos



Manual shifting frame *Parrilla móvil manual*

Manual shifting frame with visual reminders (baby S)

Parrilla móvil manual con indicación visual (baby S)



Automatic shifting frame *Parrilla móvil automática*

Automatic shifting frame allows to avoid the cutting of plastic strips during horizontal cuts

La parrilla móvil automática permite de no dañar los listones de apoyo durante los cortes horizontales



Electrowelded frame *Bastidor electrosoldado*

Electrowelded frame gives the highest resistance to the solicitations

Bastidor electrosoldado ofrece la mayor resistencia a los estrés

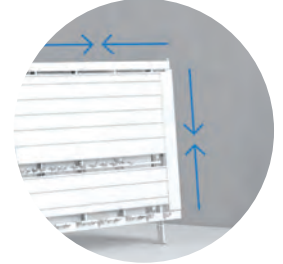

Space saver *Dimensiones reducidas*

Same performance with reduced dimensions

Mismo rendimiento con dimensiones reducidas



TECHNICAL DETAILS / DATOS TECNICOS

● Standard Standard ○ Optional Opcional × Unavailable No disponible

TECHNICAL DETAILS DATOS TECNICOS	BABY	BABY S
Motor output <i>Potencia del motor</i>		5HP
Blade diameter <i>Diámetro de la hoja</i>		250 mm
Blade r.p.m. (min) <i>Rev. de la hoja</i>		5300
Shifting frame <i>Parrilla móvil</i>	electric <i>eléctrica</i>	manual <i>manual</i>
Aluminum supports with polyzene and wheels <i>Soportes de aluminio recubiertos de polizeno y ruedas</i>	●	
Max. length of horizontal cut <i>Máximo largo de corte horizontal</i>		2500 mm
Max. height of vertical cut <i>Máxima altura de corte vertical</i>		1600 mm
Max. height of horizontal cut <i>Máxima altura de corte horizontal</i>		1400 mm
Max depth of cut <i>Máximo grueso de corte</i>		60 mm
Scoring blade diameter <i>Diámetro de hoja incisor</i>	○ 70mm	
Independent motor of scoring unit <i>Motor independiente del grupo incisor</i>		×
Motor output of scoring unit <i>Potencia motor grupo incisor</i>		-

ACCESSORIES&OPTIONALS ACCESORIOS Y OPCIONALES	BABY	BABY S
Supplementary low level stop <i>Tope suplementario</i>	○	○
Extra short cutting device (RH) <i>Dispositivo corte paneles pequeños suplementario</i>	×	×
Repetitive cutting device of horizontal strips <i>Dispositivo de cortes repetitivos de bandas horizontales</i>	○	○
Scoring unit with 2 H.M. Knives <i>Grupo incisor con 2 cuchillas</i>	○	○
Scoring unit with split saw blade <i>Grupo incisor de doble sierra</i>	○	○
Electronic vertical measuring display <i>Medidor digital para posición vertical</i>	○	○
Electronic horizontal measuring display <i>Medidor digital para posición horizontal</i>	○	○
Sliding support for narrow pieces <i>Apoyo deslizable para piezas pequeñas</i>	○	○
Dust catcher for horizontal cuttings TRK <i>Conductor de polvo para los cortes horizontales TRK</i>	○	○
Adjustable thickness stop <i>Tope de profundidad</i>	○	○
Angle cutting device <i>Dispositivo de corte inclinado</i>	○	○
Kit V-grooving with adjustable thickness stop <i>Dispositivo Alu con tope de profundidad</i>	○	○



Electrowelded frame
Bastidor electrosoldado



Aluminum lower supports coated in polyzene with retractable rollers
Soportes inferiores de aluminio recubiertos de polizeno con ruedas retráctiles



Manual shifting frame
Parrilla móvil manual



Manual cut execution
Ejecución corte manual



These are vertical panel saws responding to all cutting requirements and offering the best value for money. Thanks to a wide range of accessories, these machines guarantee performances that are typical of higher-category equipments and increase profitability.

Son las seccionadoras verticales ideales para cualquier necesidad de corte, con la mejor relación calidad/precio del mercado. Se trata de máquinas versátiles que, gracias a una amplia gama de accesorios, pueden ofrecer las prestaciones típicas de una máquina de categoría superior y aumentar la rentabilidad.

OVERALL SIZES AND CUTTING CAPACITY / DIMENSIONES Y CAPACIDADES DE CORTE

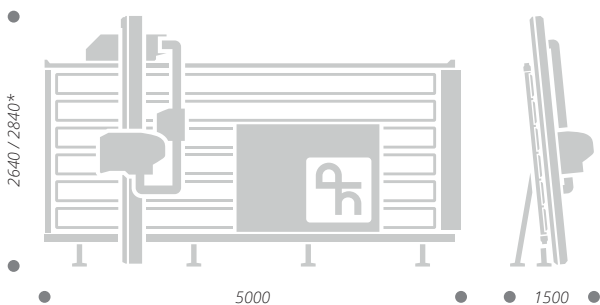

Panel saw dimensions
Dimensiones seccionadora vertical

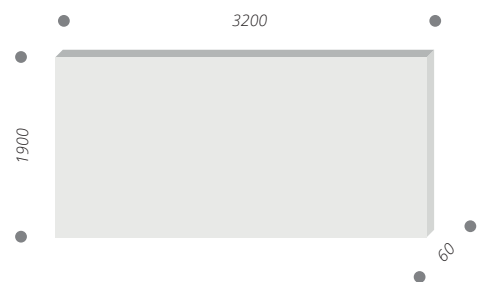

Cutting capacity
Capacidades de corte

CUTTING MATERIALS / CORTE MATERIALES

SVP 133 BABY is designed for wood - special - plastics materials cutting.

SVP 133 BABY está diseñada para cortar madera - materiales especiales - plasticos

* with scoring blade
* con hojas incisoras



Wood Panels
Paneles de madera



Special Materials
Materiales especiales



Trespa®



Insulated panels
Paneles aislantes



Corian®



Plasterboard
Pladur

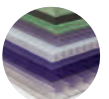

Plastic materials
Plasticos



Shifting frame markers
Parrilla móvil con indicadores

Shifting frame with visual reminders

Parrilla móvil manual con indicación visual

Manual shifting frame
Parrilla móvil manual

Manual shifting frame avoids contact with blades during horizontal cuts

La parrilla móvil manual evita el contacto con las hojas durante los cortes horizontales

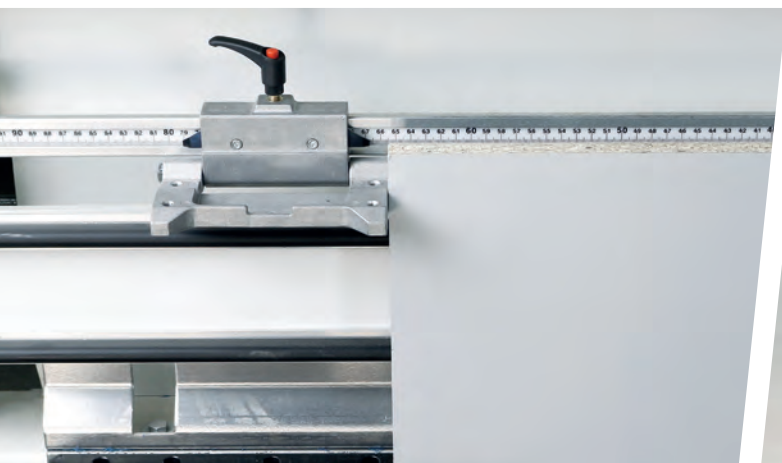

TECHNICAL DETAILS / DATOS TECNICOS

TECHNICAL DETAILS
DATOS TECNICOS

Motor output <i>Potencia del motor</i>	5HP
Blade diameter <i>Diámetro de la hoja</i>	250 mm
Blade r.p.m. (min) <i>Rev. de la hoja</i>	5300
Shifting frame <i>Parrilla móvil</i>	manual / manual
Aluminum supports with polyzene and wheels <i>Soportes de aluminio recubiertos de polizeno y ruedas</i>	●
Max. length of horizontal cut <i>Máximo largo de corte horizontal</i>	3200 mm
Max. height of vertical cut <i>Máxima altura de corte vertical</i>	1900 mm
Max. height of horizontal cut <i>Máxima altura de corte horizontal</i>	1700 mm
Max depth of cut <i>Máximo grueso de corte</i>	60 mm
Scoring blade diameter <i>Diámetro de hoja incisor</i>	○ 70mm
Independent motor of scoring unit <i>Motor independiente del grupo incisor</i>	×
Motor output of scoring unit <i>Potencia motor grupo incisor</i>	-

● Standard Standard ○ Optional Opcional × Unavailable No disponible

ACCESSORIES AND OPTIONALS
ACCESORIOS Y OPCIONALES

Supplementary low level stop <i>Tope suplementario</i>	○
Extra short cutting device (RH) <i>Dispositivo corte paneles pequeños suplementario</i>	●
Repetitive cutting device of horizontal strips <i>Dispositivo de cortes repetitivos de bandas horizontales</i>	○
Scoring unit with 2 H.M. Knives <i>Grupo incisor con 2 cuchillas</i>	○
Scoring unit with split saw blade <i>Grupo incisor de doble sierra</i>	○
Electronic vertical measuring display <i>Medidor digital para posición vertical</i>	○
Electronic horizontal measuring display <i>Medidor digital para posición horizontal</i>	○
Sliding support for narrow pieces <i>Apoyo deslizable para piezas pequeñas</i>	○
Dust catcher for horizontal cuttings TRK <i>Conductor de polvo para los cortes horizontales TRK</i>	○
Adjustable thickness stop <i>Tope de profundidad</i>	○
Angle cutting device <i>Dispositivo de corte inclinado</i>	○
Kit V-grooving with adjustable thickness stop <i>Dispositivo Alu con tope de profundidad</i>	○



Electrowelded frame
Bastidor electrosoldado



Aluminum lower supports coated in polyzene with retractable rollers
Soportes inferiores de aluminio recubiertos de polizeno con ruedas retráctiles



Automatic shifting frame
Parrilla móvil automática



Manual cut execution
Ejecución corte manual



These are vertical panel saws responding to all cutting requirements and offering the best value for money. Thanks to a wide range of accessories, these machines guarantee performances that are typical of higher-category equipments and increase profitability.

Son las seccionadoras verticales ideales para cualquier necesidad de corte, con la mejor relación calidad/precio del mercado. Se trata de máquinas versátiles que, gracias a una amplia gama de accesorios, pueden ofrecer las prestaciones típicas de una máquina de categoría superior y aumentar la rentabilidad.

OVERALL SIZES AND CUTTING CAPACITY / DIMENSIONES Y CAPACIDADES DE CORTE

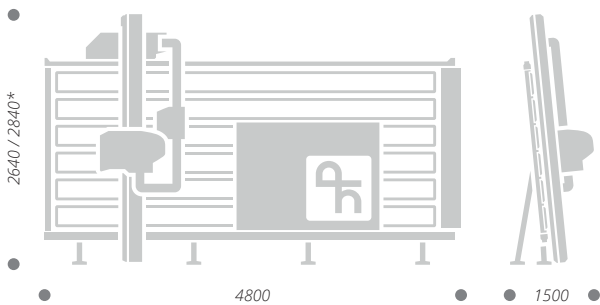

Panel saw dimensions
Dimensiones seccionadora vertical



Cutting capacity
Capacidades de corte

CUTTING MATERIALS / CORTE MATERIALES

SVP 133 PLUS is designed for wood - special - plastics materials cutting.

SVP 133 Plus está diseñada para cortar madera - materiales especiales - plásticos

* with scoring blade
* con hojas incisoras



Wood Panels
Paneles de madera



Special Materials
Materiales especiales



Trespa®



Insulated panels
Paneles aislantes



Corian®



Plasterboard
Pladur

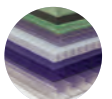

Plastic materials
Plásticos



New saw head
Tapa renovada

New protective cover for better control and protection

Nueva cobertura protectora para un mejor control y protección



Automatic shifting frame
Parrilla móvil automática

Automatic shifting frame allows to avoid the cutting of plastic strips during horizontal cuts

La parrilla móvil automática permite de no dañar los listones de apoyo durante los cortes horizontales



TECHNICAL DETAILS / DATOS TECNICOS

TECHNICAL DETAILS DATOS TECNICOS

Motor output <i>Potencia del motor</i>	5HP
Blade diameter <i>Diámetro de la hoja</i>	250 mm
Blade r.p.m. (min) <i>Rev. de la hoja</i>	5300
Shifting frame <i>Parrilla móvil</i>	electric <i>eléctrica</i>
Aluminum supports with polyzene and wheels <i>Soportes de aluminio recubiertos de polizeno y ruedas</i>	●
Max. length of horizontal cut <i>Máximo largo de corte horizontal</i>	3200 mm
Max. height of vertical cut <i>Máxima altura de corte vertical</i>	1900 mm
Max. height of horizontal cut <i>Máxima altura de corte horizontal</i>	1700 mm
Max depth of cut <i>Máximo grueso de corte</i>	60 mm
Scoring blade diameter <i>Diámetro de hoja incisor</i>	○ 70mm
Independent motor of scoring unit <i>Motor independiente del grupo incisor</i>	×
Motor output of scoring unit <i>Potencia motor grupo incisor</i>	-

● Standard
Standard ○ Optional
Opcional × Unavailable
No disponible

ACCESSORIES AND OPTIONALS ACCESORIOS Y OPCIONALES

Supplementary low level stop <i>Tope suplementario</i>	○
Extra short cutting device (RH) <i>Dispositivo corte paneles pequeños suplementario</i>	●
Repetitive cutting device of horizontal strips <i>Dispositivo de cortes repetitivos de bandas horizontales</i>	○
Scoring unit with 2 H.M. Knives <i>Grupo incisor con 2 cuchillas</i>	○
Scoring unit with split saw blade <i>Grupo incisor de doble sierra</i>	○
Electronic vertical measuring display <i>Medidor digital para posición vertical</i>	○
Electronic horizontal measuring display <i>Medidor digital para posición horizontal</i>	○
Sliding support for narrow pieces <i>Apoyo deslizable para piezas pequeñas</i>	○
Dust catcher for horizontal cuttings TRK <i>Conductor de polvo para los cortes horizontales TRK</i>	○
Adjustable thickness stop <i>Tope de profundidad</i>	○
Angle cutting device <i>Dispositivo de corte inclinado</i>	○
Kit V-grooving with adjustable thickness stop <i>Dispositivo Alu con tope de profundidad</i>	○

SVP 133
AUTOMATIC
 100% MADE IN ITALY



Electrowelded frame
 Bastidor electrosoldado



Aluminum lower supports
 coated in polyzene with
 retractable rollers
 Soportes inferiores de
 aluminio recubiertos de
 polizeno con ruedas retráctiles



Automatic shifting frame
 Parrilla móvil automática



Automatic cut execution
 Ejecución corte automático



These are vertical panel saws responding to all cutting requirements and offering the best value for money. Thanks to a wide range of accessories, these machines guarantee performances that are typical of higher-category equipments and increase profitability.

Son las seccionadoras verticales ideales para cualquier necesidad de corte, con la mejor relación calidad/precio del mercado. Se trata de máquinas versátiles que, gracias a una amplia gama de accesorios, pueden ofrecer las prestaciones típicas de una máquina de categoría superior y aumentar la rentabilidad.

OVERALL SIZES AND CUTTING CAPACITY / DIMENSIONES Y CAPACIDADES DE CORTE

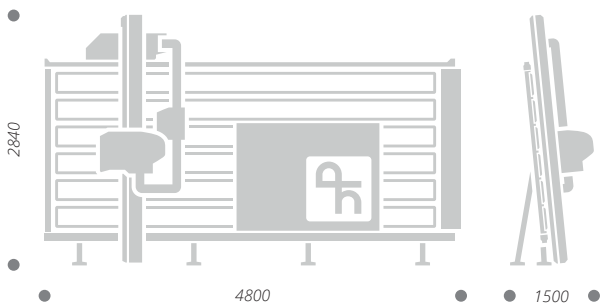

Panel saw dimensions
 Dimensiones seccionadora vertical



Cutting capacity
 Capacidades de corte

CUTTING MATERIALS / CORTE MATERIALES

SVP 133 Automatic is designed for wood - special - plastics materials cutting.

SVP 133 Automatica está diseñada para cortar madera - materiales especiales - plasticos



Wood Panels
 Paneles de madera



Special Materials
 Materiales especiales



Trespa®



Insulated panels
 Paneles aislantes



Corian®



Plasterboard
 Pladur

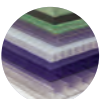

Plastic materials
 Plasticos



Space saver

Dimensiones reducidas

Same performance with reduced dimensions

Mismo rendimiento con dimensiones reducidas

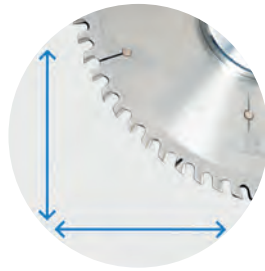

Automatic vertical horizontal cuts

Cortes automático verticales y horizontales

Automatic horizontal and vertical cuts with with speed variator

Corte automático horizontal y vertical con variador de velocidad



Electrowelded frame

Bastidor electrosoldado

Electrowelded frame gives the highest resistance to the solicitations

Bastidor electrosoldado ofrece la mayor resistencia a los estrés



Automatic shifting frame

Parrilla móvil automática

Automatic shifting frame allows to avoid the cutting of plastic strips during horizontal cuts

La parrilla móvil automática permite de no dañar los listones de apoyo durante los cortes horizontales



TECHNICAL DETAILS / DATOS TECNICOS

● Standard Standard ○ Optional Opcional ✕ Unavailable No disponible

TECHNICAL DETAILS / DATOS TECNICOS

Motor output <i>Potencia del motor</i>	6HP
Blade diameter <i>Diámetro de la hoja</i>	250 mm
Blade r.p.m. (min) <i>Rev. de la hoja</i>	5300
Shifting frame <i>Parrilla móvil</i>	pneumatic <i>neumática</i>
Aluminum supports with polyzene and wheels <i>Soportes de aluminio recubiertos de polizeno y ruedas</i>	●
Max. length of horizontal cut <i>Máximo largo de corte horizontal</i>	3200 mm
Max. height of vertical cut <i>Máxima altura de corte vertical</i>	1900 mm
Max. height of horizontal cut <i>Máxima altura de corte horizontal</i>	1700 mm
Max depth of cut <i>Máximo grueso de corte</i>	60 mm
Scoring blade diameter <i>Diámetro de hoja incisor</i>	○ 70mm
Independent motor of scoring unit <i>Motor independiente del grupo incisor</i>	✕
Motor output of scoring unit <i>Potencia motor grupo incisor</i>	-

ACCESSORIES AND OPTIONALS / ACCESORIOS Y OPCIONALES

Supplementary low level stop <i>Tope suplementario</i>	○
Extra short cutting device (RH) <i>Dispositivo corte paneles pequeños suplementario</i>	●
Repetitive cutting device of horizontal strips <i>Dispositivo de cortes repetitivos de bandas horizontales</i>	○
Scoring unit with 2 H.M. Knives <i>Grupo incisor con 2 cuchillas</i>	○
Scoring unit with split saw blade <i>Grupo incisor de doble sierra</i>	○
Electronic vertical measuring display <i>Medidor digital para posición vertical</i>	○
Electronic horizontal measuring display <i>Medidor digital para posición horizontal</i>	○
Sliding support for narrow pieces <i>Apoyo deslizable para piezas pequeñas</i>	●
Dust catcher for horizontal cuttings TRK <i>Conductor de polvo para los cortes horizontales TRK</i>	○
Adjustable thickness stop <i>Tope de profundidad</i>	○
Angle cutting device <i>Dispositivo de corte inclinado</i>	○
Kit V-grooving with adjustable thickness stop <i>Dispositivo Alu con tope de profundidad</i>	○

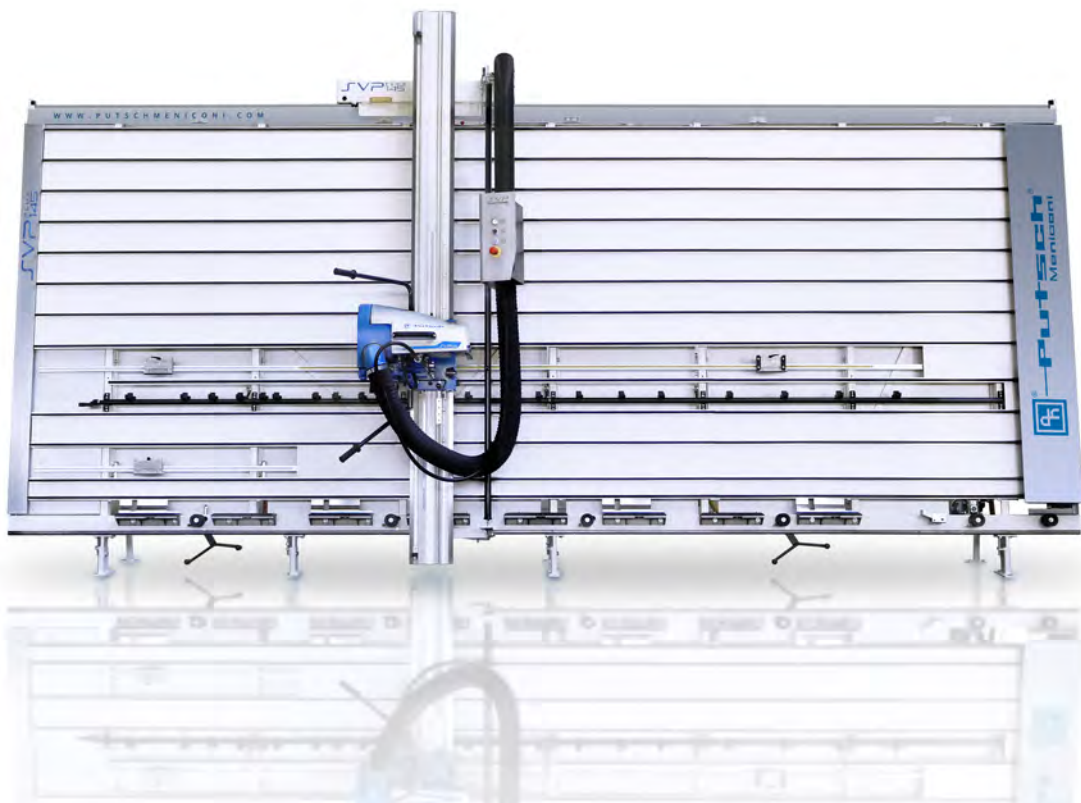

SVP SERIES 145

These are vertical panel saws responding to all cutting requirements and offering the best value for money. Thanks to a wide range of accessories, these machines guarantee performances that are typical of higher-category equipments and increase profitability.

Son las seccionadoras verticales ideales para cualquier necesidad de corte, con la mejor relación calidad/precio del mercado. Se trata de máquinas versátiles que, gracias a una amplia gama de accesorios, pueden ofrecer las prestaciones típicas de una máquina de categoría superior y aumentar la rentabilidad.





Electrowelded frame
Bastidor electrosoldado



Aluminum lower supports coated in polyzene with retractable rollers
Soportes inferiores de aluminio recubiertos de polizeno con ruedas retráctiles



Manual shifting frame
Parrilla móvil manual



Manual cut execution
Ejecución corte manual



These are vertical panel saws responding to all cutting requirements and offering the best value for money. Thanks to a wide range of accessories, these machines guarantee performances that are typical of higher-category equipments and increase profitability.

Son las seccionadoras verticales ideales para cualquier necesidad de corte, con la mejor relación calidad/precio del mercado. Se trata de máquinas versátiles que, gracias a una amplia gama de accesorios, pueden ofrecer las prestaciones típicas de una máquina de categoría superior y aumentar la rentabilidad.

OVERALL SIZES AND CUTTING CAPACITY / DIMENSIONES Y CAPACIDADES DE CORTE

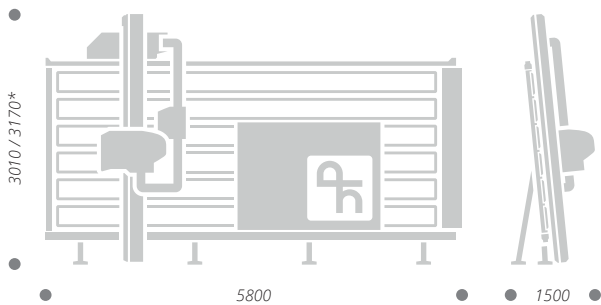

Panel saw dimensions
Dimensiones seccionadora vertical

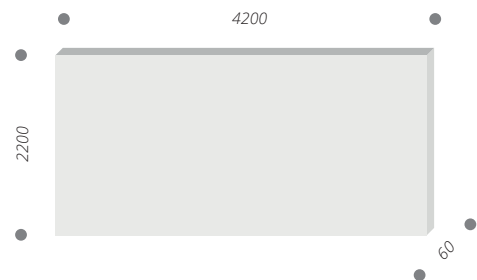

Cutting capacity
Capacidades de corte

CUTTING MATERIALS / CORTE MATERIALES

SVP 145 S is designed for wood - special - plastics materials cutting.

SVP 145 S está diseñada para cortar madera - materiales especiales - plasticos

* with scoring blade
* con hojas incisoras



Wood Panels
Paneles de madera



Special Materials
Materiales especiales



Trespa®



Insulated panels
Paneles aislantes

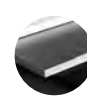

Corian®



Plasterboard
Pladur

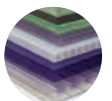

Plastic materials
Plasticos



Shifting frame markers
Parrilla móvil con indicadores

Shifting frame with visual reminders

Parrilla móvil manual con indicación visual



Manual shifting frame
Parrilla móvil manual

Manual shifting frame avoids contact with blades during horizontal cuts

Parrilla móvil manual evita el contacto con las hojas durante los cortes horizontales



Electrowelded frame
Bastidor electrosoldado

Electrowelded frame gives the highest resistance to the solicitations

Bastidor electrosoldado ofrece la mayor resistencia a los estrés



Lower supports with rollers
Soportes inferiores con ruedas

Aluminium lower supports with polyzene carry-overs

Soportes inferiores de aluminio recubiertos de polizeno con ruedas retráctiles



TECHNICAL DETAILS / DATOS TECNICOS

● Standard Standard ○ Optional Opcional ✕ Unavailable No disponible

TECHNICAL DETAILS / DATOS TECNICOS

Motor output <i>Potencia del motor</i>	5HP
Blade diameter <i>Diámetro de la hoja</i>	250 mm
Blade r.p.m. (min) <i>Rev. de la hoja</i>	5300
Shifting frame <i>Parrilla móvil</i>	manual / manual
Aluminum supports with polyzene and wheels <i>Soportes de aluminio recubiertos de polizeno y ruedas</i>	●
Max. length of horizontal cut <i>Máximo largo de corte horizontal</i>	4200 mm
Max. height of vertical cut <i>Máxima altura de corte vertical</i>	2200 mm
Max. height of horizontal cut <i>Máxima altura de corte horizontal</i>	2080 mm
Max depth of cut <i>Máximo grueso de corte</i>	60 mm
Scoring blade diameter <i>Diámetro de hoja incisor</i>	○ 70mm
Independent motor of scoring unit <i>Motor independiente del grupo incisor</i>	✕
Motor output of scoring unit <i>Potencia motor grupo incisor</i>	-

ACCESSORIES AND OPTIONALS / ACCESORIOS Y OPCIONALES

Supplementary low level stop <i>Tope suplementario</i>	○
Extra short cutting device (RH) <i>Dispositivo corte paneles pequeños suplementario</i>	○
Repetitive cutting device of horizontal strips <i>Dispositivo de cortes repetitivos de bandas horizontales</i>	○
Scoring unit with 2 H.M. Knives <i>Grupo incisor con 2 cuchillas</i>	○
Scoring unit with split saw blade <i>Grupo incisor de doble sierra</i>	○
Electronic vertical measuring display <i>Medidor digital para posición vertical</i>	○
Electronic horizontal measuring display <i>Medidor digital para posición horizontal</i>	○
Sliding support for narrow pieces <i>Apoyo deslizable para piezas pequeñas</i>	○
Dust catcher for horizontal cuttings TRK <i>Conductor de polvo para los cortes horizontales TRK</i>	○
Adjustable thickness stop <i>Tope de profundidad</i>	○
Angle cutting device <i>Dispositivo de corte inclinado</i>	○
Kit V-grooving with adjustable thickness stop <i>Dispositivo Alu con tope de profundidad</i>	○



Electrowelded frame
Bastidor electrosoldado



Aluminum lower supports coated in polyzene with retractable rollers
Soportes inferiores de aluminio recubiertos de polizeno con ruedas retráctiles



Automatic shifting frame
Parrilla móvil automática



Automatic cut execution
Ejecución corte automático



These are vertical panel saws responding to all cutting requirements and offering the best value for money. Thanks to a wide range of accessories, these machines guarantee performances that are typical of higher-category equipments and increase profitability.

Son las seccionadoras verticales ideales para cualquier necesidad de corte, con la mejor relación calidad/precio del mercado. Se trata de máquinas versátiles que, gracias a una amplia gama de accesorios, pueden ofrecer las prestaciones típicas de una máquina de categoría superior y aumentar la rentabilidad.

OVERALL SIZES AND CUTTING CAPACITY / DIMENSIONES Y CAPACIDADES DE CORTE

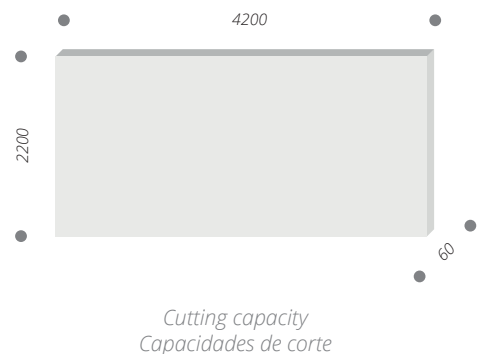
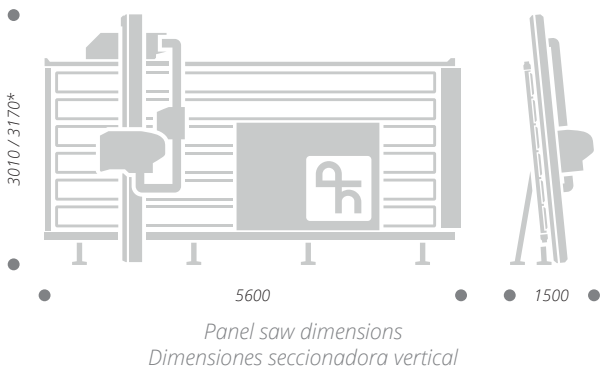

CUTTING MATERIALS / CORTE MATERIALES

SVP 145 PLUS is designed for wood - special - plastics materials cutting.

SVP 145 PLUS está diseñada para cortar madera - materiales especiales - plasticos

* with scoring blade
* con hojas incisoras



Wood Panels
Paneles de madera



Special Materials
Materiales especiales



Trespa®



Insulated panels
Paneles aislantes



Corian®



Plasterboard
Pladur

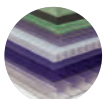

Plastic materials
Plasticos



New saw head Tapa renovada

New protective cover for better control and protection

Nueva cobertura protectora para un mejor control y protección



Automatic shifting frame Parrilla móvil automática

Automatic shifting frame allows to avoid the cutting of plastic strips during horizontal cuts

La parrilla móvil automática permite de no dañar los listones de apoyo durante los cortes horizontales



Electrowelded frame Bastidor electrosoldado

Electrowelded frame gives the highest resistance to the solicitations

Bastidor electrosoldado ofrece la mayor resistencia a los estrés



Horizontal cutting Corte horizontal

Easy horizontal trimming

Fácil recorte horizontal



TECHNICAL DETAILS / DATOS TECNICOS

● Standard Standard ○ Optional Opcional ✕ Unavailable No disponible

TECHNICAL DETAILS DATOS TECNICOS	
Motor output Potencia del motor	5HP
Blade diameter Diámetro de la hoja	250 mm
Blade r.p.m. (min) Rev. de la hoja	5300
Shifting frame Parrilla móvil	electric eléctrica
Aluminum supports with polyzene and wheels Soportes de aluminio recubiertos de polizeno y ruedas	●
Max. length of horizontal cut Máximo largo de corte horizontal	4200 mm
Max. height of vertical cut Máxima altura de corte vertical	2200 mm
Max. height of horizontal cut Máxima altura de corte horizontal	2080 mm
Max depth of cut Máximo grueso de corte	60 mm
Scoring blade diameter Diámetro de hoja incisor	○ 70mm
Independent motor of scoring unit Motor independiente del grupo incisor	✕
Motor output of scoring unit Potencia motor grupo incisor	-

ACCESSORIES AND OPTIONALS ACCESORIOS Y OPCIONALES	
Supplementary low level stop Tope suplementario	○
Extra short cutting device (RH) Dispositivo corte paneles pequeños suplementario	○
Repetitive cutting device of horizontal strips Dispositivo de cortes repetitivos de bandas horizontales	○
Scoring unit with 2 H.M. Knives Grupo incisor con 2 cuchillas	○
Scoring unit with split saw blade Grupo incisor de doble sierra	○
Electronic vertical measuring display Medidor digital para posición vertical	○
Electronic horizontal measuring display Medidor digital para posición horizontal	○
Sliding support for narrow pieces Apoyo deslizable para piezas pequeñas	○
Dust catcher for horizontal cuttings TRK Conductor de polvo para los cortes horizontales TRK	○
Adjustable thickness stop Tope de profundidad	○
Angle cutting device Dispositivo de corte inclinado	○
Kit V-grooving with adjustable thickness stop Dispositivo Alu con tope de profundidad	○

SVP145
AUTOMATIC
 100% MADE IN ITALY



Electrowelded frame
 Bastidor electrosoldado



Aluminum lower supports coated in polyzene with retractable rollers
 Soportes inferiores de aluminio recubiertos de polizeno con ruedas retráctiles



Automatic shifting frame
 Parrilla móvil automática



Automatic cut execution
 Ejecución corte manual



These are vertical panel saws responding to all cutting requirements and offering the best value for money. Thanks to a wide range of accessories, these machines guarantee performances that are typical of higher-category equipments and increase profitability.

Son las seccionadoras verticales ideales para cualquier necesidad de corte, con la mejor relación calidad/precio del mercado. Se trata de máquinas versátiles que, gracias a una amplia gama de accesorios, pueden ofrecer las prestaciones típicas de una máquina de categoría superior y aumentar la rentabilidad.

OVERALL SIZES AND CUTTING CAPACITY / DIMENSIONES Y CAPACIDADES DE CORTE

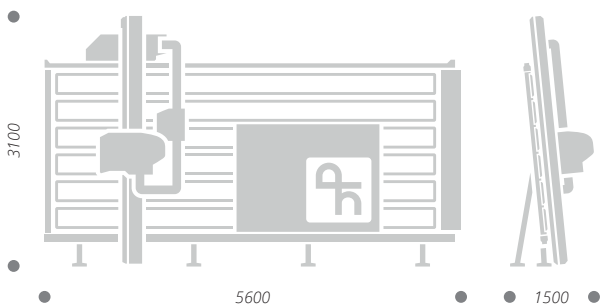

Panel saw dimensions
 Dimensiones seccionadora vertical

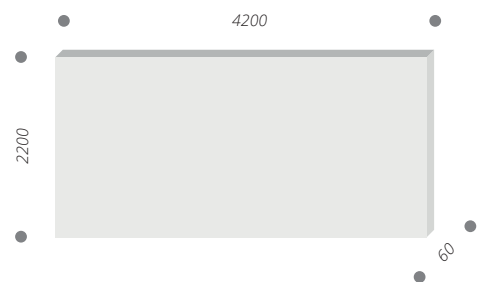

Cutting capacity
 Capacidades de corte

CUTTING MATERIALS / CORTE MATERIALES

SVP 145 Automatic is designed for wood - special - plastics materials cutting.

SVP 145 Automatica está diseñada para cortar madera - materiales especiales - plasticos

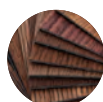

Wood Panels
 Paneles de madera



Special Materials
 Materiales especiales



Trespa®



Insulated panels
 Paneles aislantes



Corian®



Plasterboard
 Pladur

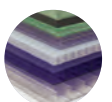

Plastic materials
 Plasticos



Space Saver

Dimensiones reducidas

Same performance with reduced dimensions

Mismo rendimiento con dimensiones reducidas

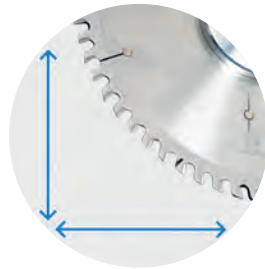

Automatic vertical horizontal cuts

Cortes automático verticales y horizontales

Automatic horizontal and vertical cuts with with speed variator

Corte automático horizontal y vertical con variador de velocidad



Electrowelded frame

Bastidor electrosoldado

Electrowelded frame gives the highest resistance to the solicitations

Bastidor electrosoldado ofrece la mayor resistencia a los estrés



Automatic shifting frame

Parrilla móvil automática

Automatic shifting frame allows to avoid the cutting of plastic strips during horizontal cuts

La parrilla móvil automática permite de no dañar los listones de apoyo durante los cortes horizontales



TECHNICAL DETAILS / DATOS TECNICOS

TECHNICAL DETAILS DATOS TECNICOS	
Motor output Potencia del motor	6HP
Blade diameter Diámetro de la hoja	250 mm
Blade r.p.m. (min) Rev. de la hoja	5300
Shifting frame Parrilla móvil	pneumatic neumática
Aluminum supports with polyzene and wheels Soportes de aluminio recubiertos de polizeno y ruedas	●
Max. length of horizontal cut Máximo largo de corte horizontal	4200 mm
Max. height of vertical cut Máxima altura de corte vertical	2200 mm
Max. height of horizontal cut Máxima altura de corte horizontal	2080 mm
Max depth of cut Máximo grueso de corte	60 mm
Scoring blade diameter Diámetro de hoja incisor	○ 70mm
Independent motor of scoring unit Motor independiente del grupo incisor	×
Motor output of scoring unit Potencia motor grupo incisor	-

ACCESSORIES AND OPTIONALS ACCESORIOS Y OPCIONALES	
Supplementary low level stop Tope suplementario	○
Extra short cutting device (RH) Dispositivo corte paneles pequeños suplementario	○
Repetitive cutting device of horizontal strips Dispositivo de cortes repetitivos de bandas horizontales	○
Scoring unit with 2 H.M. Knives Grupo incisor con 2 cuchillas	×
Scoring unit with split saw blade Grupo incisor de doble sierra	○
Electronic vertical measuring display Medidor digital para posición vertical	○
Electronic horizontal measuring display Medidor digital para posición horizontal	○
Sliding support for narrow pieces Apoyo deslizable para piezas pequeñas	●
Dust catcher for horizontal cuttings TRK Conductor de polvo para los cortes horizontales TRK	○
Adjustable thickness stop Tope de profundidad	○
Angle cutting device Dispositivo de corte inclinado	○
Kit V-grooving with adjustable thickness stop Dispositivo Alu con tope de profundidad	○

● Standard Standard ○ Optional Opcional × Unavailable No disponible

SVP PLUS 145 ALU
100% MADE IN ITALY



Electrowelded frame
Bastidor electrosoldado



Aluminum lower supports coated in polyzene with retractable rollers
Soportes inferiores de aluminio recubiertos de polizeno con ruedas retráctiles



Automatic shifting frame
Parrilla móvil automática



Manual cut execution
Ejecución corte manual



V grooving executions with ALU-KIT
Ejecución corte con KIT-ALU



These are vertical panel saws responding to all cutting requirements and offering the best value for money. Thanks to a wide range of accessories, these machines guarantee performances that are typical of higher-category equipments and increase profitability.

Son las seccionadoras verticales ideales para cualquier necesidad de corte, con la mejor relación calidad/precio del mercado. Se trata de máquinas versátiles que, gracias a una amplia gama de accesorios, pueden ofrecer las prestaciones típicas de una máquina de categoría superior y aumentar la rentabilidad.

OVERALL SIZES AND CUTTING CAPACITY / DIMENSIONES Y CAPACIDADES DE CORTE

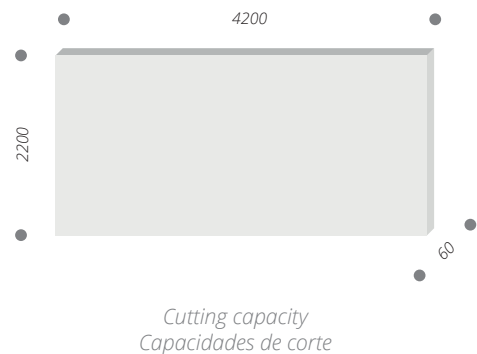
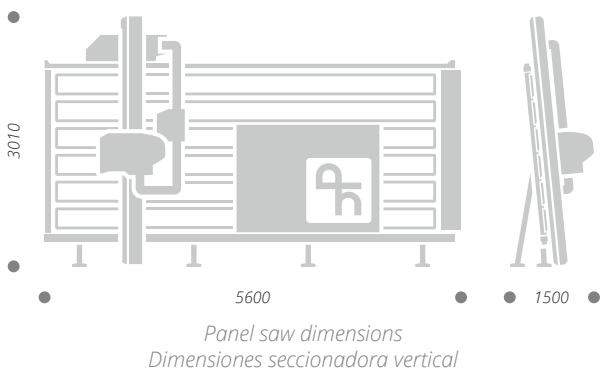

CUTTING MATERIALS / CORTE MATERIALES

SVP 145 Plus Alu is designed for wood - special - plastics materials cutting.
SVP 145 PLUS ALU está diseñada para cortar madera - materiales especiales - plasticos

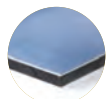

Composites Materials
Materiaux composite



Sandwich



HPL



Special Materials
Materiales especiales



Trespa®



Plasterboard
Pladur



Corian®

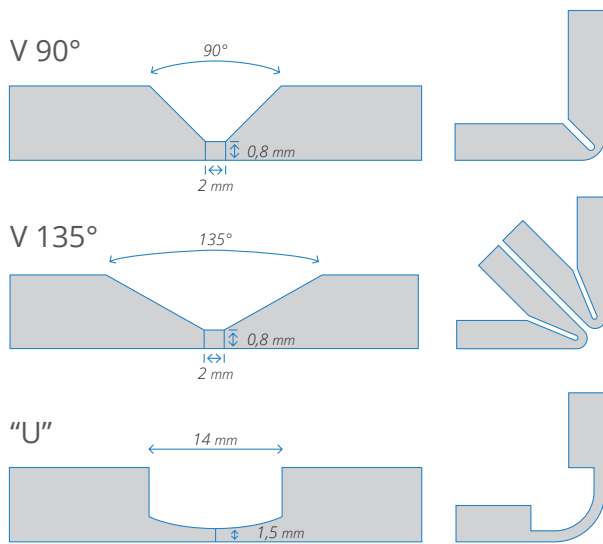

Alu Kit
Kit Alu

V grooving on composites materials, sandwich type, ACM (Alucobond®, etc.) solid surface (Corian®, etc.)

Fresados sobre tableros compuestos tipo sandwich ACM (Alucobond®, etc.), superficies solidas (Corian®, etc.)



Adjustable thickness stop
Tope de profundidad

Adjustable thickness stop for grooving operations

Tope de profundidad para operaciones de fresado

CUT AND GROOVING ON COMPOSITE PANELS FOR DIFFERENT PROFILES

CORTE Y FRESADO SOBRE TABLEROS COMPUESTOS DE DIFERENTES PERFILES

TECHNICAL DETAILS / DATOS TECNICOS

TECHNICAL DETAILS DATOS TECNICOS	
Motor output Potencia del motor	5HP
Blade diameter Diámetro de la hoja	250 mm
Blade r.p.m. (min) Rev. de la hoja	5300
Shifting frame Parrilla móvil	electric eléctrica
Aluminum supports with polyzene and wheels Soportes de aluminio recubiertos de polizeno y ruedas	●
Max. length of horizontal cut Máximo largo de corte horizontal	4200 mm
Max. height of vertical cut Máxima altura de corte vertical	2200 mm
Max. height of horizontal cut Máxima altura de corte horizontal	2080 mm
Max depth of cut Máximo grueso de corte	60 mm
Scoring blade diameter Diámetro de hoja incisor	-
Independent motor of scoring unit Motor independiente del grupo incisor	-
Motor output of scoring unit Potencia motor grupo incisor	-

ACCESSORIES AND OPTIONALS ACCESORIOS Y OPCIONALES	
Supplementary low level stop Tope suplementario	○
Extra short cutting device (RH) Dispositivo corte paneles pequeños suplementario	○
Repetitive cutting device of horizontal strips Dispositivo de cortes repetitivos de bandas horizontales	○
Scoring unit with 2 H.M. Knives Grupo incisor con 2 cuchillas	○
Scoring unit with split saw blade Grupo incisor de doble sierra	○
Electronic vertical measuring display Medidor digital para posición vertical	○
Electronic horizontal measuring display Medidor digital para posición horizontal	○
Sliding support for narrow pieces Apoyo deslizable para piezas pequeñas	○
Dust catcher for horizontal cuttings TRK Conductor de polvo para los cortes horizontales TRK	○
Adjustable thickness stop Tope de profundidad	○
Angle cutting device Dispositivo de corte inclinado	○
Kit V-grooving with adjustable thickness stop Dispositivo Alu con tope de profundidad	●

● Standard Standard ○ Optional Opcional ✕ Unavailable No disponible

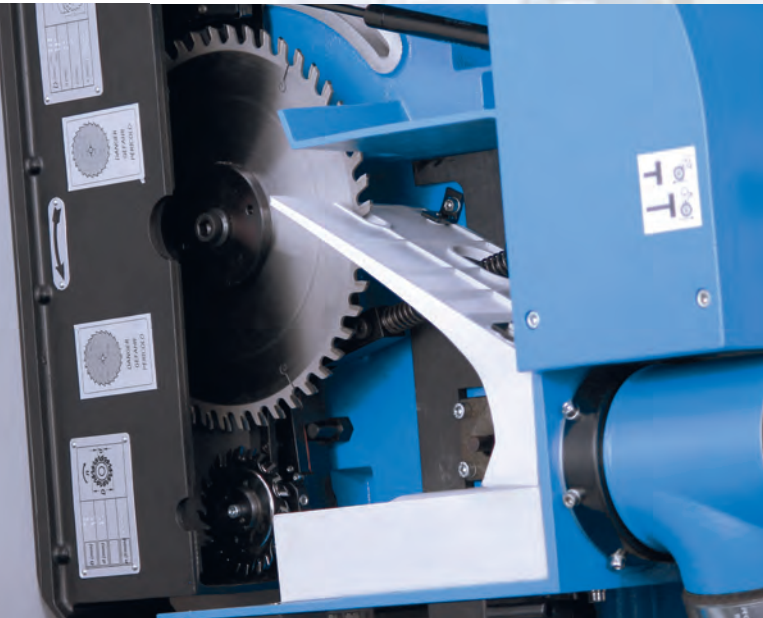
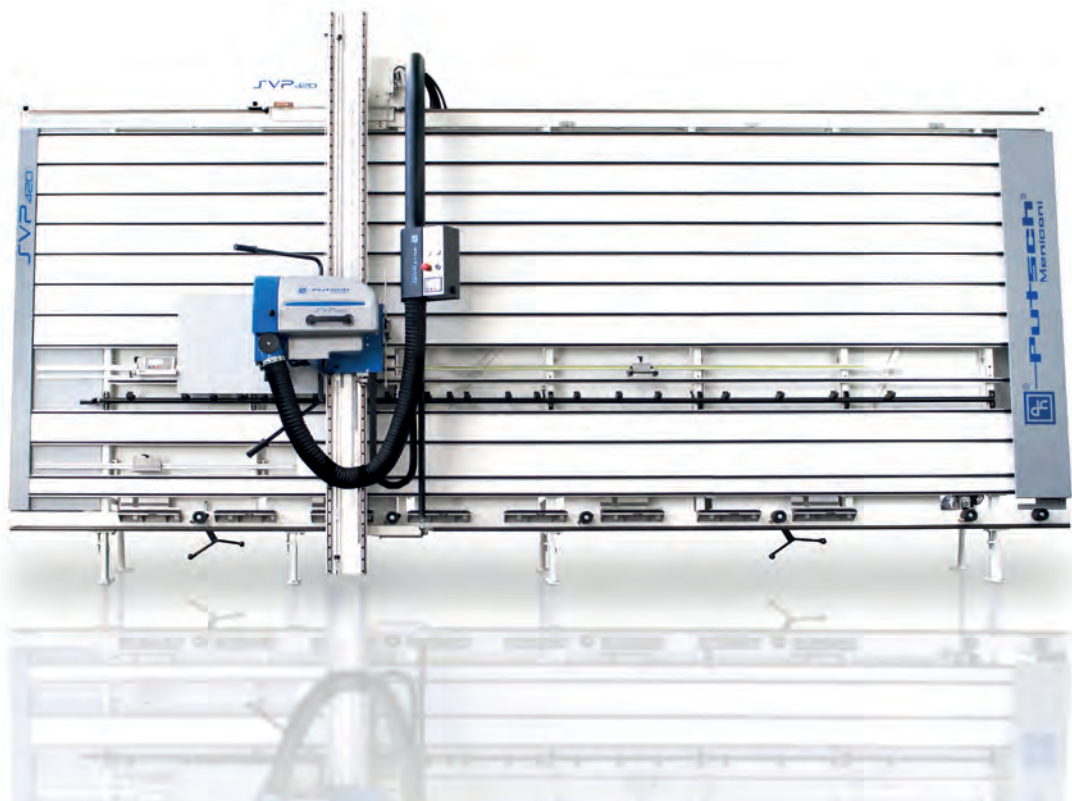

SVP SERIES 320-420

These are vertical panel saws suitable for cutting melamine boards where scoring unit is required to get a clean cut without scratching. Thanks to a wide range of accessories, these machines guarantee performances that are typical of higher-category equipments and increase profitability.

Son las seccionadoras verticales ideales para cualquier necesidad de corte, especialmente tableros melaminicos donde se requiere un incisor para un acabado limpio sin rayas. Se trata de máquinas versátiles que, gracias a una amplia gama de accesorios, pueden ofrecer las prestaciones típicas de una máquina de categoría superior y aumentar la rentabilidad.

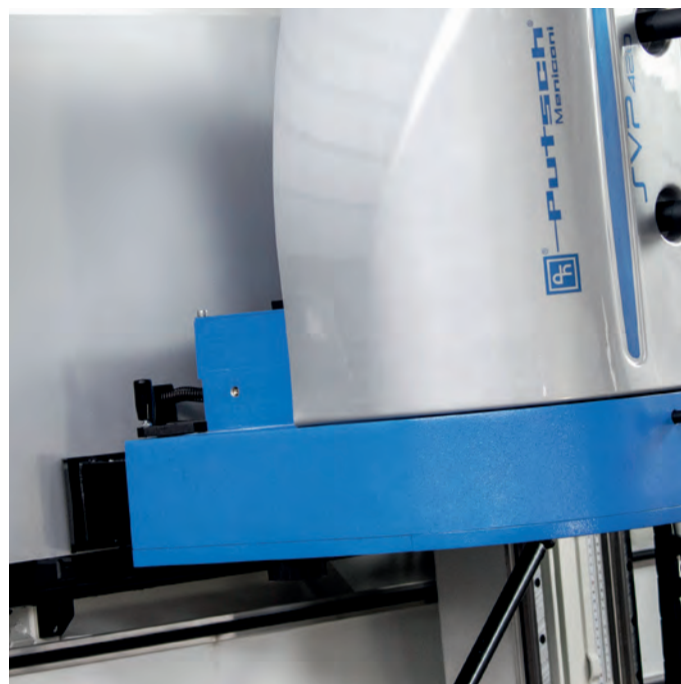

SVP MANUAL
320
100% MADE IN ITALY



Electrowelded frame
Bastidor electrosoldado



Aluminum lower supports
coated in polyzene with
retractable rollers
Soportes inferiores de
aluminio recubiertos de
polizeno con ruedas retráctiles



Automatic shifting frame
Parrilla móvil automática



Manual cut execution
Ejecución corte manual



Saw carriage sliding along
two linear guides
Deslizamiento del carro a lo
largo de dos guías lineales



Scoring unit with split
saw blade
Grupo incisor de doble
sierra



Scoring unit with
independent motor
Motor independiente por el
grupo incisor



This new machine has some special features and especially the sliding of the saw carriage on 2 linear guides, that is the most accurate guiding system available today. This system has been already experienced by Putsch Meniconi on the first machine introduced in the 2004. Independent motorized scoring system with automatic power up by plunging the same by means of the front lever.

La característica principal de esta nueva máquina es dada por el desplazamiento del carro, con relativo grupo de corte, sobre 2 guías lineales: sistema extremadamente preciso y ya experimentado por la Putsch-Meniconi desde el 2004, cuando fue presentada la primera máquina con este exclusivo sistema. Sistema con motor independiente del grupo incisor con encendido automático, cuando se actúa el embrague del grupo incisor por tramite de la palanca frontal.

OVERALL SIZES AND CUTTING CAPACITY / DIMENSIONES Y CAPACIDADES DE CORTE

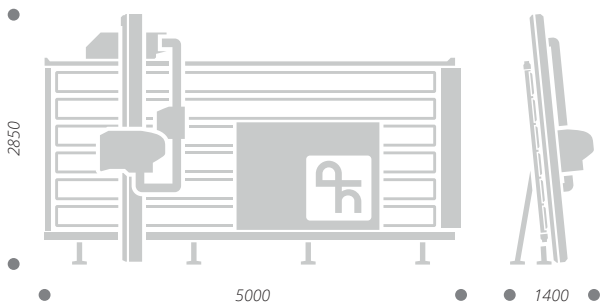

Panel saw dimensions
Dimensiones seccionadora vertical



Cutting capacity
Capacidades de corte

CUTTING MATERIALS / CORTE MATERIALES

SVP 320 MANUAL is designed for wood - special - plastics materials cutting.

SVP 320 MANUAL está diseñada para cortar madera - materiales especiales - plasticos



Wood Panels
Paneles de madera



Special Materials
Materiales especiales



Trespa®



Insulated panels
Paneles aislantes



Corian®



Plasterboard
Pladur

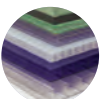

Plastic materials
Plasticos



Double motor
Doble motor

Saw unit with double independent motor with mechanic plunging

Grupo de corte con doble motor con entrada mecánica



Linear guides
Dos guías prismáticas

Sliding of saw carriage along two linear guides that allows a better precision

Deslizamiento del carro a lo largo de dos guías prismáticas



Scoring unit with split saw blade
Incisor de doble sierra

Scoring unit with double saw blade creates a pre-cutting and allows a cutting more precise and faster.

El grupo incisor de doble sierra actúa un pre-corte y permite un acabado más limpio.



Electrowelded frame
Bastidor electrosoldado

Electrowelded frame gives the highest resistance to the solicitations

Bastidor electrosoldado ofrece la mayor resistencia a los estrés



TECHNICAL DETAILS / DATOS TECNICOS

TECHNICAL DETAILS *DATOS TECNICOS*

Motor output <i>Potencia del motor</i>	5 HP
Blade diameter <i>Diámetro de la hoja</i>	250 mm
Blade r.p.m. (min) <i>Rev. de la hoja</i>	5300
Shifting frame <i>Parrilla móvil</i>	electric <i>eléctrica</i>
Aluminum supports with polyzene and wheels <i>Soportes de aluminio recubiertos de polizeno y ruedas</i>	●
Max. length of horizontal cut <i>Máximo largo de corte horizontal</i>	3200 mm
Max. height of vertical cut <i>Máxima altura de corte vertical</i>	1900 mm
Max. height of horizontal cut <i>Máxima altura de corte horizontal</i>	1700 mm
Max depth of cut <i>Máximo grueso de corte</i>	60 mm
Scoring blade diameter <i>Diámetro de hoja incisor</i>	80 mm
Independent motor of scoring unit <i>Motor independiente del grupo incisor</i>	●
Motor output of scoring unit <i>Potencia motor grupo incisor</i>	0,25 HP

ACCESSORIES AND OPTIONALS *ACCESORIOS Y OPCIONALES*

Supplementary low level stop <i>Tope suplementario</i>	○
Extra short cutting device (RH) <i>Dispositivo corte paneles pequeños suplementario</i>	●
Repetitive cutting device of horizontal strips <i>Dispositivo de cortes repetitivos de bandas horizontales</i>	○
Scoring unit with 2 H.M. Knives <i>Grupo incisor con 2 cuchillas</i>	×
Scoring unit with split saw blade <i>Grupo incisor de doble sierra</i>	●
Electronic vertical measuring display <i>Medidor digital para posición vertical</i>	○
Electronic horizontal measuring display <i>Medidor digital para posición horizontal</i>	○
Sliding support for narrow pieces <i>Apoyo deslizable para piezas pequeñas</i>	●
Dust catcher for horizontal cuttings TRK <i>Conductor de polvo para los cortes horizontales TRK</i>	○
Adjustable thickness stop <i>Tope de profundidad</i>	○
Angle cutting device <i>Dispositivo de corte inclinado</i>	○
Kit V-grooving with adjustable thickness stop <i>Dispositivo Alu con tope de profundidad</i>	○

● Standard
Standard ○ Optional
Opcional × Unavailable
No disponible

SVP AUTOMATIC **320**
100% MADE IN ITALY



Electrowelded frame
Bastidor electrosoldado



Aluminum lower supports coated in polyzene with retractable rollers
Soportes inferiores de aluminio recubiertos de polizeno con ruedas retráctiles



Automatic shifting frame
Parrilla móvil automática



Automatic cut execution
Ejecución corte automático



Saw carriage sliding along two linear guides
Deslizamiento de la cabeza a lo largo de dos guías lineales



Scoring unit with split saw blade
Grupo incisor de doble sierra



Scoring unit with independent motor
Motor independiente por el grupo incisor



This new machine has some special features and especially the sliding of the saw carriage on 2 linear guides, that is the most accurate guiding system available today. This system has been already experienced by Putsch Meniconi on the first machine introduced in the 2004. Independent motorized scoring system with automatic power up by plunging the same by means of the front lever.

La característica principal de esta nueva máquina es dada por el desplazamiento del carro, con relativo grupo de corte, sobre 2 guías lineales: sistema extremadamente preciso y ya experimentado por la Putsch-Meniconi ya desde el 2004, cuando fue presentada la primera máquina con exclusivo sistema. Sistema con motor independiente del grupo incisor con encendido automático, cuando se actúa el embrague del grupo incisor por tramite de la palanca frontal.

OVERALL SIZES AND CUTTING CAPACITY / DIMENSIONES Y CAPACIDADES DE CORTE

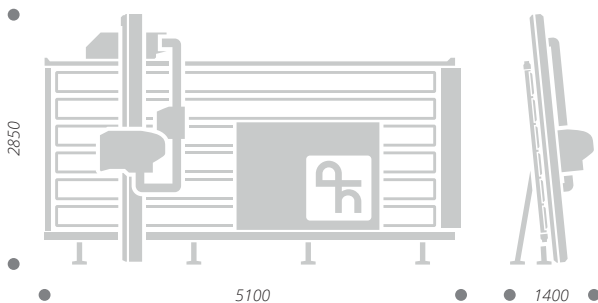

Panel saw dimensions
Dimensiones seccionadora vertical



Cutting capacity
Capacidades de corte

CUTTING MATERIALS / CORTE MATERIALES

SVP 320 MANUAL is designed for wood - special - plastics materials cutting.

SVP 320 MANUAL está diseñada para cortar madera - materiales especiales - plasticos



Wood Panels
Paneles de madera



Special Materials
Materiales especiales



Trespa®



Insulated panels
Paneles aislantes



Corian®



Plasterboard
Pladur

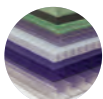

Plastic materials
Plasticos



Double motor
Doble motor

Saw unit with double independent motor with mechanic plunging

Grupo de corte con doble motor con entrada mecánica



Scoring unit with split saw blade
Incisor de doble sierra

Scoring unit with double saw blade creates a pre-cutting and allows a cutting more precise and faster.

El grupo incisor de doble sierra actúa un pre-corte y permite un acabado más limpio.

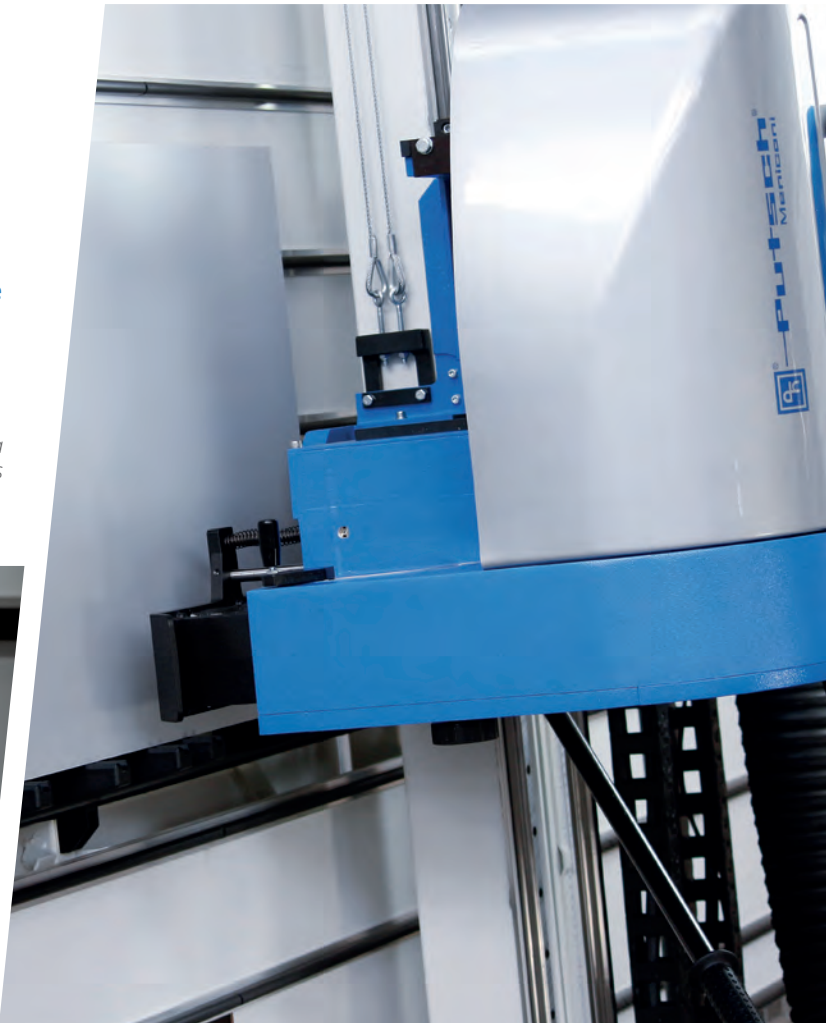

TECHNICAL DETAILS / DATOS TECNICOS

TECHNICAL DETAILS DATOS TECNICOS

Motor output <i>Potencia del motor</i>	6 HP
Blade diameter <i>Diámetro de la hoja</i>	250 mm
Blade r.p.m. (min) <i>Rev. de la hoja</i>	5300
Shifting frame <i>Parrilla móvil</i>	pneumatic <i>neumática</i>
Aluminum supports with polyzene and wheels <i>Soportes de aluminio recubiertos de polizeno y ruedas</i>	●
Max. length of horizontal cut <i>Máximo largo de corte horizontal</i>	3200 mm
Max. height of vertical cut <i>Máxima altura de corte vertical</i>	1900 mm
Max. height of horizontal cut <i>Máxima altura de corte horizontal</i>	1700 mm
Max depth of cut <i>Máximo grueso de corte</i>	60 mm
Scoring blade diameter <i>Diámetro de hoja incisor</i>	80 mm
Independent motor of scoring unit <i>Motor independiente del grupo incisor</i>	●
Motor output of scoring unit <i>Potencia motor grupo incisor</i>	0,25 HP

● Standard
Standard

○ Optional
Opcional

✕ Unavailable
No disponible

ACCESSORIES AND OPTIONALS ACCESORIOS Y OPCIONALES

Supplementary low level stop <i>Tope suplementario</i>	○
Extra short cutting device (RH) <i>Dispositivo corte paneles pequeños suplementario</i>	●
Repetitive cutting device of horizontal strips <i>Dispositivo de cortes repetitivos de bandas horizontales</i>	○
Scoring unit with 2 H.M. Knives <i>Grupo incisor con 2 cuchillas</i>	✕
Scoring unit with split saw blade <i>Grupo incisor de doble sierra</i>	●
Electronic vertical measuring display <i>Medidor digital para posición vertical</i>	○
Electronic horizontal measuring display <i>Medidor digital para posición horizontal</i>	○
Sliding support for narrow pieces <i>Apoyo deslizable para piezas pequeñas</i>	●
Dust catcher for horizontal cuttings TRK <i>Conductor de polvo para los cortes horizontales TRK</i>	○
Adjustable thickness stop <i>Tope de profundidad</i>	○
Angle cutting device <i>Dispositivo de corte inclinado</i>	○
Kit V-grooving with adjustable thickness stop <i>Dispositivo Alu con tope de profundidad</i>	○

SVP MANUAL 420
100% MADE IN ITALY



Saw carriage sliding along two linear guides
Deslizamiento del carro a lo largo de dos guías lineales



Aluminum lower supports coated in polyzene with retractable rollers
Soportes inferiores de aluminio recubiertos de polizeno con ruedas retráctiles



Scoring unit with split saw blade
Grupo incisor de doble sierra



Scoring unit with independent motor
Motor independiente por el grupo incisor



Electrowelded frame
Bastidor electrosoldado



Automatic shifting frame
Parrilla móvil automática



Manual cut execution
Ejecución corte manual



This new machine has some special features and especially the sliding of the saw carriage on 2 linear guides, that is the most accurate guiding system available today. This system has been already experienced by Putsch Meniconi on the first machine introduced in the 2004. Independent motorized scoring system with automatic power up by plunging the same by means of the front lever.

La característica principal de esta nueva máquina es dada por el desplazamiento del carro, con relativo grupo de corte, sobre 2 guías lineales: sistema extremadamente preciso y ya experimentado por la Putsch-Meniconi ya desde el 2004, cuando fue presentada la primera máquina con exclusivo sistema. Sistema con motor independiente del grupo incisor con encendido automático, cuando se actúa el embrague del grupo incisor por tramite de la palanca frontal.

OVERALL SIZES AND CUTTING CAPACITY / DIMENSIONES Y CAPACIDADES DE CORTE

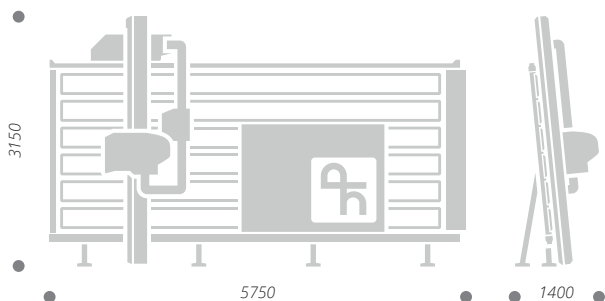

Panel saw dimensions
Dimensiones seccionadora vertical



Cutting capacity
Capacidades de corte

CUTTING MATERIALS / CORTE MATERIALES

SVP 320 AUTOMATIC is designed for wood - special - plastics materials cutting.

SVP 320 AUTOMATICA está diseñada para cortar madera - materiales especiales - plasticos



Wood Panels
Paneles de madera



Special Materials
Materiales especiales



Trespa®



Insulated panels
Paneles aislantes



Corian®



Plasterboard
Pladur

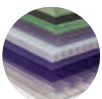

Plastic materials
Plasticos



Double motorization dedicated to the scoring blade for a more precise and clean processing.

Doble motorización de las hojas para un acabado más preciso y limpio

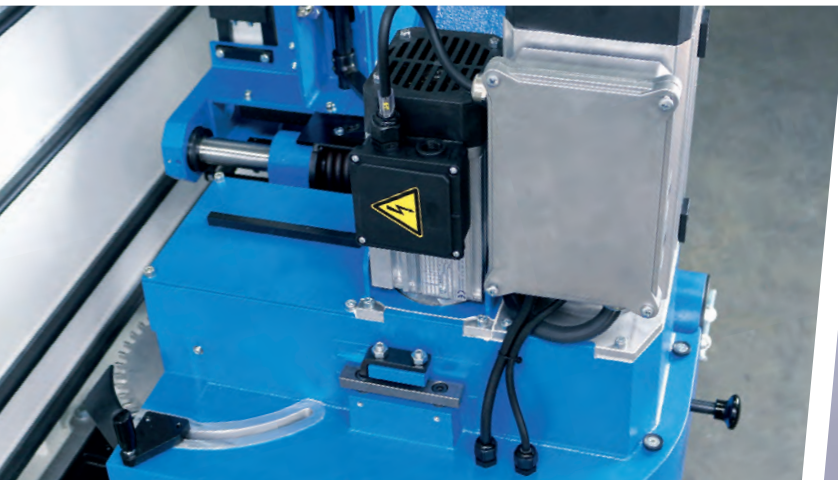

TECHNICAL DETAILS / DATOS TECNICOS

TECHNICAL DETAILS DATOS TECNICOS

Motor output <i>Potencia del motor</i>	5 HP
Blade diameter <i>Diámetro de la hoja</i>	250 mm
Blade r.p.m. (min) <i>Rev. de la hoja</i>	5300
Shifting frame <i>Parrilla móvil</i>	electric <i>eléctrica</i>
Aluminum supports with polyzene and wheels <i>Soportes de aluminio recubiertos de polizeno y ruedas</i>	●
Max. length of horizontal cut <i>Máximo largo de corte horizontal</i>	4200 mm
Max. height of vertical cut <i>Máxima altura de corte vertical</i>	2200 mm
Max. height of horizontal cut <i>Máxima altura de corte horizontal</i>	2080 mm
Max depth of cut <i>Máximo grueso de corte</i>	60 mm
Scoring blade diameter <i>Diámetro de hoja incisor</i>	80 mm
Independent motor of scoring unit <i>Motor independiente del grupo incisor</i>	●
Motor output of scoring unit <i>Potencia motor grupo incisor</i>	0,25 HP

● Standard
Standard ○ Optional
Opcional ✕ Unavailable
No disponible

ACCESSORIES AND OPTIONALS ACCESORIOS Y OPCIONALES

Supplementary low level stop <i>Tope suplementario</i>	○
Extra short cutting device (RH) <i>Dispositivo corte paneles pequeños suplementario</i>	○
Repetitive cutting device of horizontal strips <i>Dispositivo de cortes repetitivos de bandas horizontales</i>	○
Scoring unit with 2 H.M. Knives <i>Grupo incisor con 2 cuchillas</i>	✕
Scoring unit with split saw blade <i>Grupo incisor de doble sierra</i>	●
Electronic vertical measuring display <i>Medidor digital para posición vertical</i>	○
Electronic horizontal measuring display <i>Medidor digital para posición horizontal</i>	○
Sliding support for narrow pieces <i>Apoyo deslizable para piezas pequeñas</i>	●
Dust catcher for horizontal cuttings TRK <i>Conductor de polvo para los cortes horizontales TRK</i>	○
Adjustable thickness stop <i>Tope de profundidad</i>	○
Angle cutting device <i>Dispositivo de corte inclinado</i>	○
Kit V-grooving with adjustable thickness stop <i>Dispositivo Alu con tope de profundidad</i>	○

SVP AUTOMATIC
420
100% MADE IN ITALY



Saw carriage sliding along two linear guides
Deslizamiento del carro a lo largo de dos guías lineales



Aluminum lower supports coated in polyzene with retractable rollers
Soportes inferiores de aluminio recubiertos de polizeno con ruedas retráctiles



Scoring unit with split saw blade
Grupo incisor de doble sierra



Scoring unit with independent motor
Motor independiente por el grupo incisor



Electrowelded frame
Bastidor electrosoldado



Automatic shifting frame
Parrilla móvil automática



Automatic cut execution
Ejecución corte automático



This new machine has some special features and especially the sliding of the saw carriage on 2 linear guides, that is the most accurate guiding system available today. This system has been already experienced by Putsch Meniconi on the first machine introduced in the 2004. Independent motorized scoring system with automatic power up by plunging the same by means of the front lever.

La característica principal de esta nueva máquina es dada por el desplazamiento del carro, con relativo grupo de corte, sobre 2 guías lineales: sistema extremadamente preciso y ya experimentado por la Putsch-Meniconi ya desde el 2004, cuando fue presentada la primera máquina con exclusivo sistema. Sistema con motor independiente del grupo incisor con encendido automático, cuando se actúa el embrague del grupo incisor por tramite de la palanca frontal.

OVERALL SIZES AND CUTTING CAPACITY / DIMENSIONES Y CAPACIDADES DE CORTE

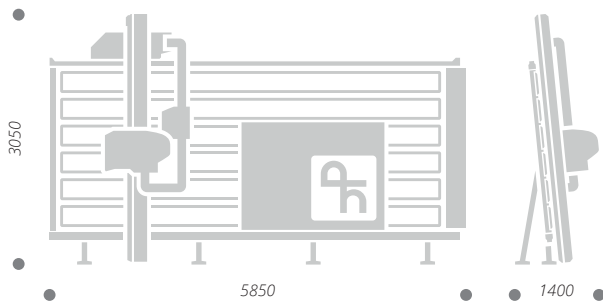

Panel saw dimensions
Dimensiones seccionadora vertical

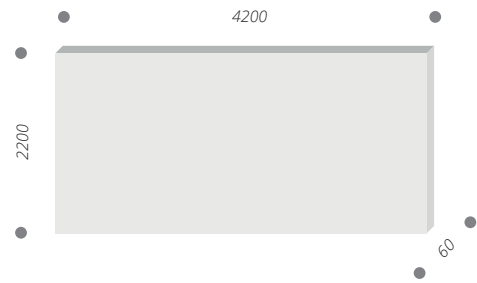

Cutting capacity
Capacidades de corte

CUTTING MATERIALS / CORTE MATERIALES

SVP 420 MANUAL is designed for wood - special - plastics materials cutting.

SVP 420 MANUAL está diseñada para cortar madera - materiales especiales - plasticos



Wood Panels
Paneles de madera



Special Materials
Materiales especiales



Trespa®



Insulated panels
Paneles aislantes



Corian®



Plasterboard
Pladur

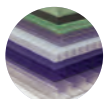

Plastic materials
Plasticos

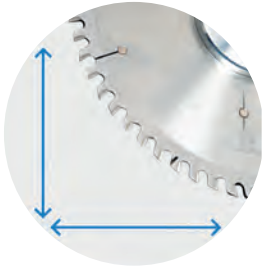

Automatic vertical horizontal cuts
Cortes automáticos verticales y horizontales

Automatic horizontal and vertical cuts with with speed variator

Corte automático horizontal y vertical con variador de velocidad



Linear guides
Dos guías prismáticas

Sliding of saw carriage along two linear guides that allows a better precision

Deslizamiento del carro a lo largo de dos guías prismáticas

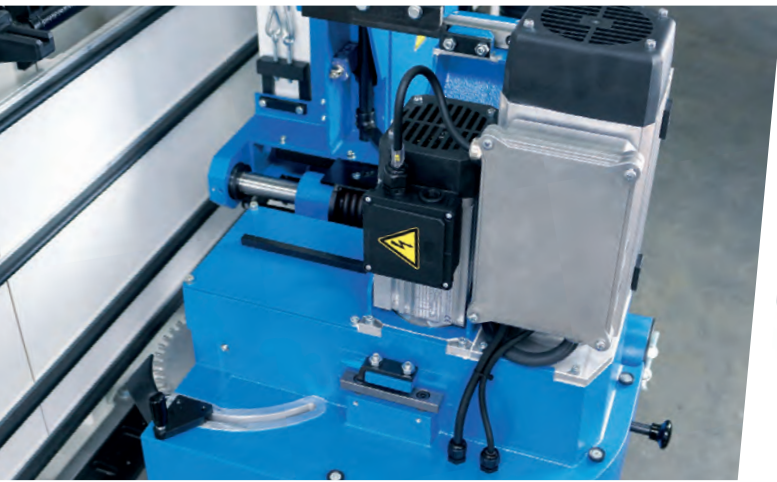

TECHNICAL DETAILS / DATOS TECNICOS

TECHNICAL DETAILS DATOS TECNICOS

Motor output <i>Potencia del motor</i>	6 HP
Blade diameter <i>Diámetro de la hoja</i>	250 mm
Blade r.p.m. (min) <i>Rev. de la hoja</i>	5300
Shifting frame <i>Parrilla móvil</i>	pneumatic <i>neumática</i>
Aluminum supports with polyzene and wheels <i>Soportes de aluminio recubiertos de polizeno y ruedas</i>	●
Max. length of horizontal cut <i>Máximo largo de corte horizontal</i>	4200 mm
Max. height of vertical cut <i>Máxima altura de corte vertical</i>	2200 mm
Max. height of horizontal cut <i>Máxima altura de corte horizontal</i>	2080 mm
Max depth of cut <i>Máximo grueso de corte</i>	60 mm
Scoring blade diameter <i>Diámetro de hoja incisor</i>	80 mm
Independent motor of scoring unit <i>Motor independiente del grupo incisor</i>	●
Motor output of scoring unit <i>Potencia motor grupo incisor</i>	0,25 HP

ACCESSORIES AND OPTIONALS ACCESORIOS Y OPCIONALES

Supplementary low level stop <i>Tope suplementario</i>	○
Extra short cutting device (RH) <i>Dispositivo corte paneles pequeños suplementario</i>	○
Repetitive cutting device of horizontal strips <i>Dispositivo de cortes repetitivos de bandas horizontales</i>	○
Scoring unit with 2 H.M. Knives <i>Grupo incisor con 2 cuchillas</i>	×
Scoring unit with split saw blade <i>Grupo incisor de doble sierra</i>	●
Electronic vertical measuring display <i>Medidor digital para posición vertical</i>	○
Electronic horizontal measuring display <i>Medidor digital para posición horizontal</i>	○
Sliding support for narrow pieces <i>Apoyo deslizable para piezas pequeñas</i>	●
Dust catcher for horizontal cuttings TRK <i>Conductor de polvo para los cortes horizontales TRK</i>	○
Adjustable thickness stop <i>Tope de profundidad</i>	○
Angle cutting device <i>Dispositivo de corte inclinado</i>	○
Kit V-grooving with adjustable thickness stop <i>Dispositivo Alu con tope de profundidad</i>	○

● Standard
Standard

○ Optional
Opcional

× Unavailable
No disponible

SVP 420
AUTOMATIC TOUCH
100% MADE IN ITALY



Electrowelded frame
Bastidor electrosoldado



Aluminum lower supports coated in polyzene with retractable rollers
Soportes inferiores de aluminio recubiertos de polizeno con ruedas retráctiles



Automatic shifting frame
Parrilla móvil automática



Automatic cut execution
Ejecución corte automático



Saw carriage sliding along two linear guides
Deslizamiento del carro a lo largo de dos guías lineales



Scoring unit with independent motor
Motor independiente por el grupo incisor



Display touch screen for cut guide
Pantalla táctil



Automatic positioning of head for horizontal cuts
Posición automática del carro para los cortes horizontales.



Automatic positioning stop vertical cuts
Tope electrónico para los cortes verticales



Scoring unit with split saw blade
Grupo incisor de doble sierra



This new machine has some special features and especially the sliding of the saw carriage on 2 linear guides, that is the most accurate guiding system available today. This system has been already experienced by Putsch Meniconi on the first machine introduced in the 2004.

La característica principal de esta nueva máquina es dada por el desplazamiento del carro, con relativo grupo de corte, sobre 2 guías lineales: sistema extremadamente preciso y ya experimentado por la Putsch-Meniconi ya desde el 2004, cuando fue presentada la primera máquina con exclusivo sistema.

OVERALL SIZES AND CUTTING CAPACITY / DIMENSIONES Y CAPACIDADES DE CORTE

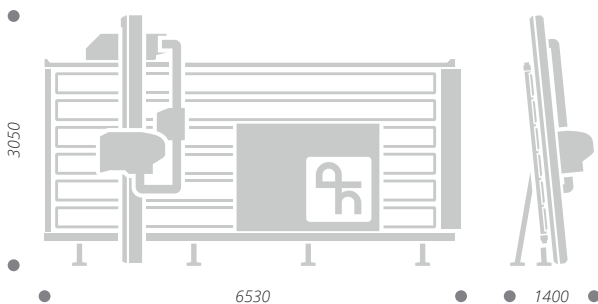

Panel saw dimensions
Dimensiones seccionadora vertical



Cutting capacity
Capacidades de corte

CUTTING MATERIALS / CORTE MATERIALES

SVP 420 AUTOMATIC TOUCH is designed for wood - special - plastics materials cutting.

SVP 420 AUTOMATIC TOUCH está diseñada para cortar madera - materiales especiales - plásticos



Wood Panels
Paneles de madera



Special Materials
Materiales especiales



Trespa®



Insulated panels
Paneles aislantes



Corian®



Plasterboard
Pladur

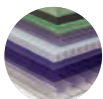

Plastic materials
Plásticos

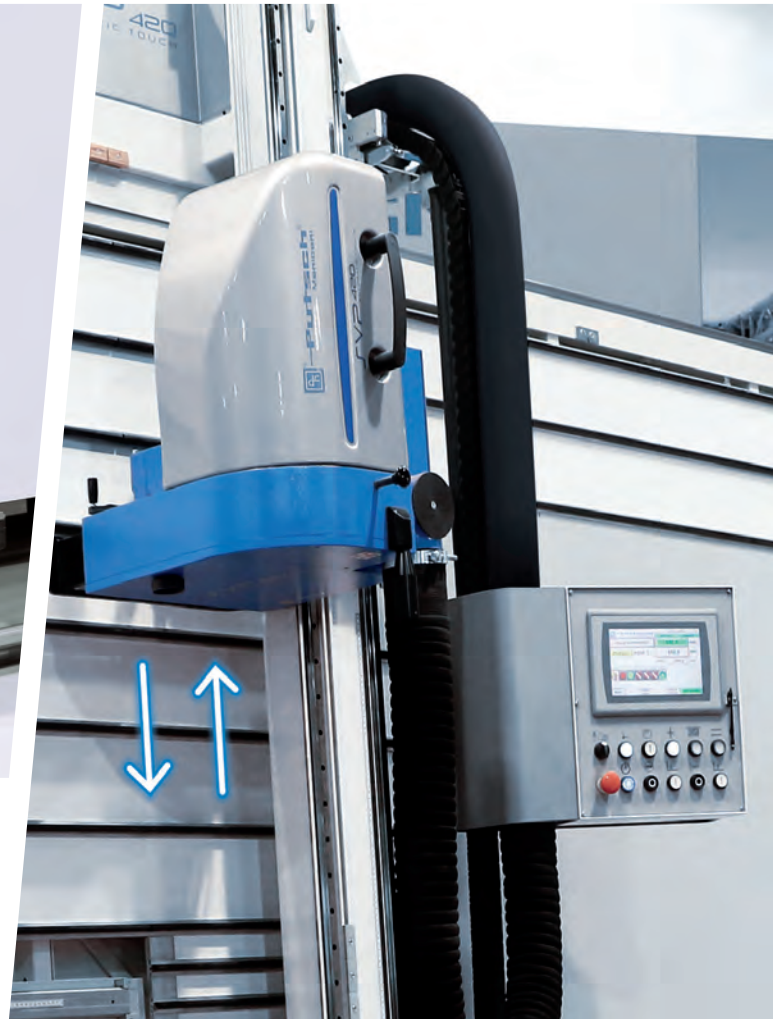
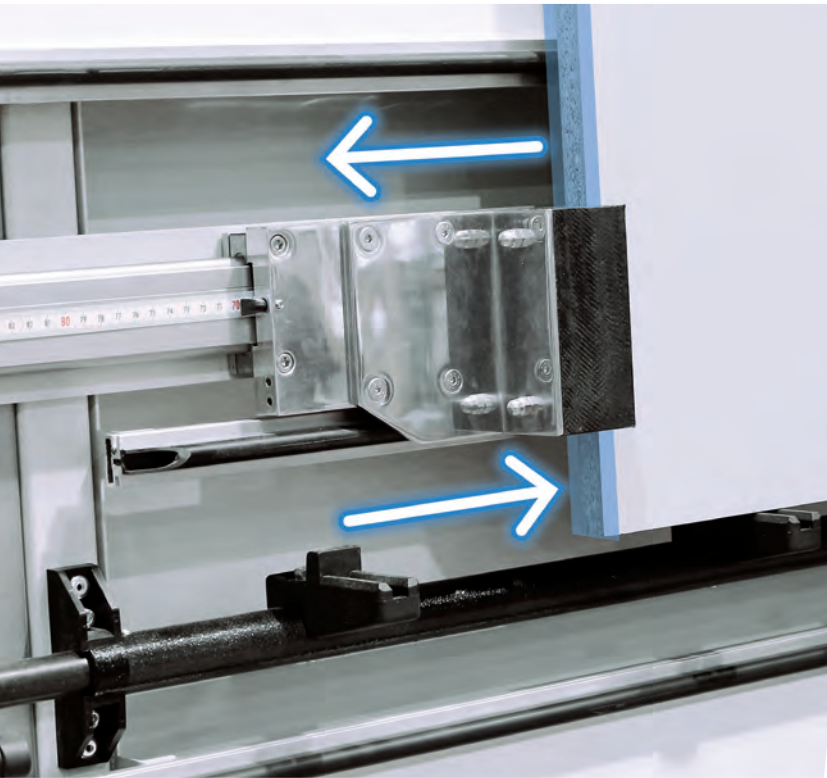

The stop positioning is automatically and quickly controlled by the software installed on the touch screen

El posicionamiento del tope se controla de forma automática y rápida, gracias al software dedicado instalado en la pantalla táctil

Automatic positioning of saw unit in horizontal cuts by touch screen -

Posicionamiento automático de la cabeza para cortes horizontales mediante pantalla táctil.

TECHNICAL DETAILS / DATOS TECNICOS

TECHNICAL DETAILS DATOS TECNICOS	
Motor output <i>Potencia del motor</i>	6 HP
Blade diameter <i>Diámetro de la hoja</i>	250 mm
Blade r.p.m. (min) <i>Rev. de la hoja</i>	5300
Shifting frame <i>Parrilla móvil</i>	pneumatic <i>neumática</i>
Aluminum supports with polyzene and wheels <i>Soportes de aluminio recubiertos de polizeno y ruedas</i>	●
Max. height of vertical cut <i>Máxima altura de corte vertical</i>	4200 mm
Max. height of horizontal cut <i>Máxima altura de corte horizontal</i>	2200 mm
Max depth of cut <i>Máximo grueso de corte</i>	2080 mm
Scoring blade diameter <i>Diámetro de hoja incisor</i>	60 mm
Independent motor of scoring unit <i>Motor independiente del grupo incisor</i>	80 mm
Motore gruppo incisore indipendente <i>Moteur du groupe inciseur indépendant</i>	●
Motor output of scoring unit <i>Potencia motor grupo incisor</i>	0,25 HP

● Standard
Standard ○ Optional
Opcional ✕ Unavailable
No disponible

ACCESSORIES AND OPTIONALS ACCESORIOS Y OPCIONALES	
Supplementary low level stop <i>Tope suplementario</i>	○
Extra short cutting device (RH) <i>Dispositivo corte paneles pequeños suplementario</i>	○
Repetitive cutting device of horizontal strips <i>Dispositivo de cortes repetitivos de bandas horizontales</i>	●
Scoring unit with 2 H.M. Knives <i>Grupo incisor con 2 cuchillas</i>	✕
Scoring unit with split saw blade <i>Grupo incisor de doble sierra</i>	●
Electronic vertical measuring display <i>Medidor digital para posición vertical</i>	●
Electronic horizontal measuring display <i>Medidor digital para posición horizontal</i>	●
Sliding support for narrow pieces <i>Apoyo deslizable para piezas pequeñas</i>	●
Dust catcher for horizontal cuttings TRK <i>Conductor de polvo para los cortes horizontales TRK</i>	○
Adjustable thickness stop <i>Tope de profundidad</i>	○
Angle cutting device <i>Dispositivo de corte inclinado</i>	○
Kit V-grooving with adjustable thickness stop <i>Dispositivo Alu con tope de profundidad</i>	○

SVP 420
MANUAL
CS-H
100% MADE IN ITALY

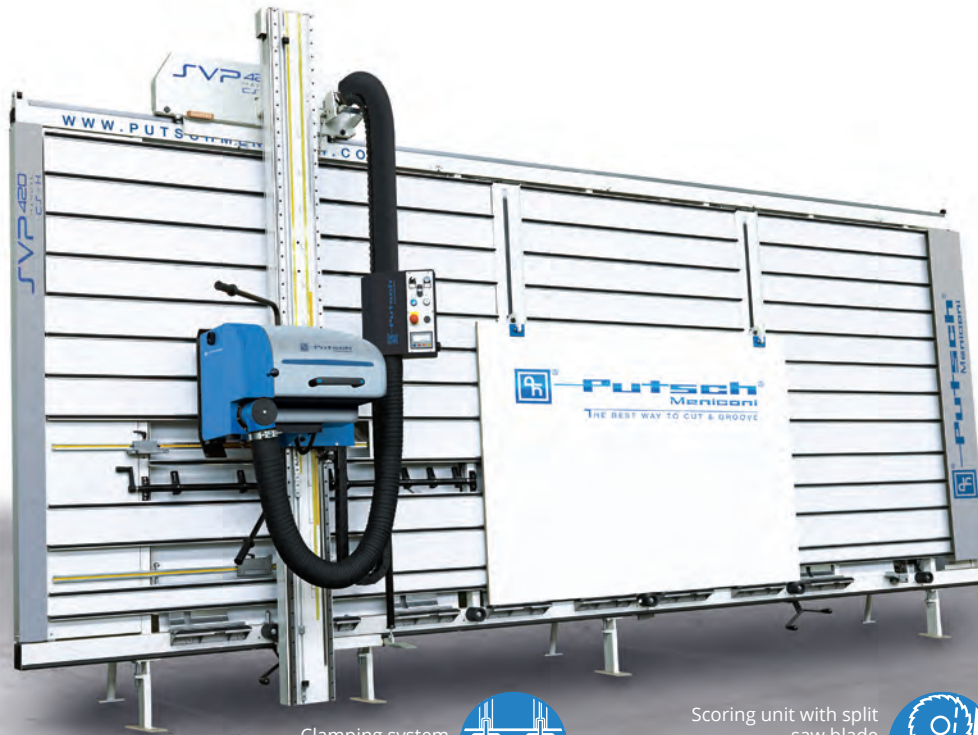

Clamping system
Sistema de pinzas



Scoring unit with split saw blade
Grupo incisor de doble sierra



Electrowelded frame
Bastidor electrosoldado



Aluminum lower supports coated in polyzene with retractable rollers
Soportes inferiores de aluminio recubiertos de polizeno con ruedas retráctiles



Automatic shifting frame
Parrilla móvil automática



Manual cut execution
Ejecución corte manual



Saw carriage sliding along two linear guides
Deslizamiento del carro a lo largo de dos guías lineales



Scoring unit with independent motor
Motor independiente por el grupo incisor



From almost 60 years of cutting experience, we introduce a new vertical panel saw that offers the possibility to trim also the panel bottom part to avoid heavy rotation operations.

The special clamps are Putsch Meniconi exclusive system. The clamps are positioned at distance to allow the lifting of heavy and large panels.

A partir de la experiencia de casi 60 años en máquinas seccionadoras, se añade una nueva seccionadora vertical que ofrece la posibilidad de recortar la parte inferior de los tableros, evitando así las incómodas operaciones de rotación de los ableros para que se puedan recortar la parte inferior de los mismos. Las pinzas están colocadas a una distancia tal para permitir el levantamiento de los tableros pesados y grandes.

OVERALL SIZES AND CUTTING CAPACITY / DIMENSIONES Y CAPACIDADES DE CORTE

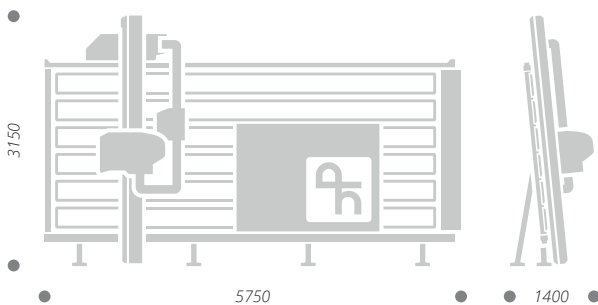

Panel saw dimensions
Dimensiones seccionadora vertical



Cutting capacity
Capacidades de corte

CUTTING MATERIALS / CORTE MATERIALES

SVP 420 CS H is designed for wood - special - plastics materials cutting.

SVP 420 CS H está diseñada para cortar madera - materiales especiales - plasticos



Wood Panels
Paneles de madera



Special Materials
Materiales especiales



Trespa®



Insulated panels
Paneles aislantes



Corian®



Plasterboard
Pladur

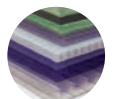

Plastic materials
Plasticos

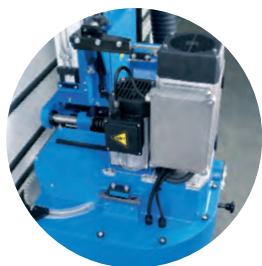

Double motor
Doble motor

Saw unit with double independent motor and mechanic plunging, avoids overcharging of main motor

Grupo de corte con doble motor con entrada mecánica del incisor evita la sobrecarga del motor principal



Linear guides
Dos guías prismáticas

Sliding of saw carriage along two linear guides that allows a better precision

Deslizamiento del carro a lo largo de dos guías prismáticas



Scoring unit with split saw blade
Incisor de doble sierra

Scoring unit with double saw blade creates a pre-cutting and allows a cutting more precise and faster.

El grupo incisor de doble sierra actúa un pre-corte y permite un acabo más limpio.

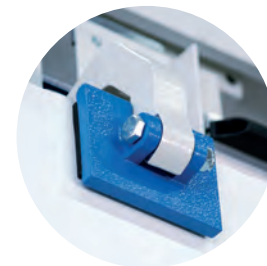

Clamping system
Sistema de pinzas

System of steady clamps, that allows the lifting of panels to make trimmings on lower parts

Sistema de pinzas, que permite el levantamiento de paneles para recortar la parte inferior de los tableros

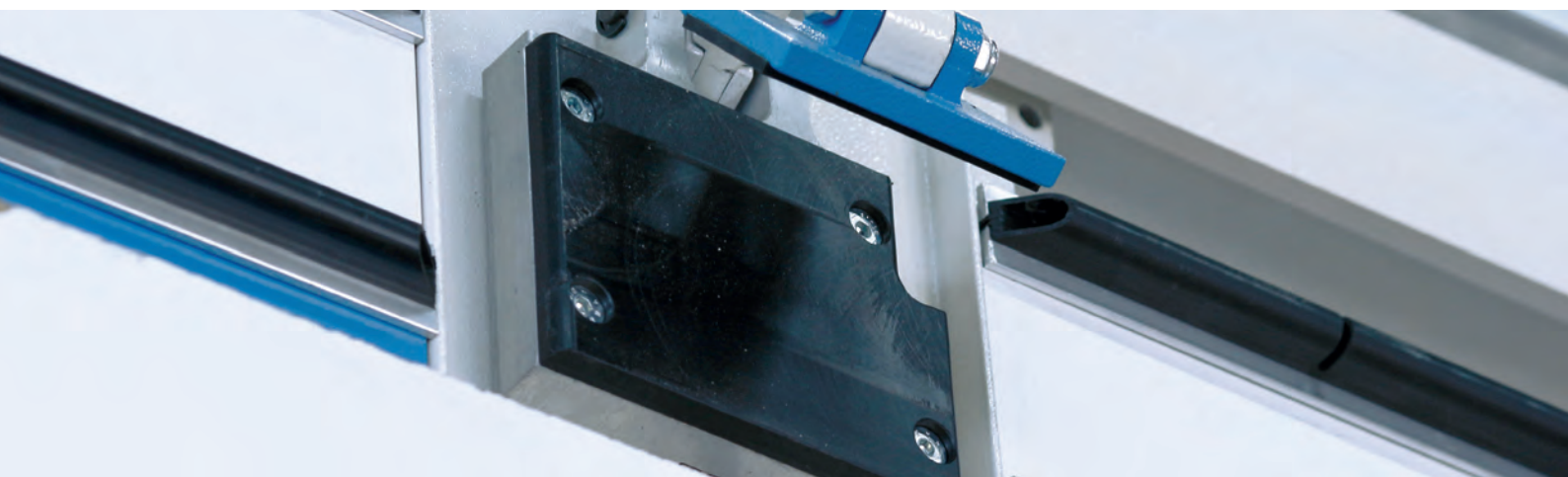

TECHNICAL DETAILS / DATOS TECNICOS

● Standard Standard ○ Optional Opcional ✕ Unavailable No disponible

TECHNICAL DETAILS / DATOS TECNICOS

Motor output <i>Potencia del motor</i>	5 HP
Blade diameter <i>Diámetro de la hoja</i>	250 mm
Blade r.p.m. (min) <i>Rev. de la hoja</i>	5300
Shifting frame <i>Parrilla móvil</i>	electric <i>eléctrica</i>
Aluminum supports with polyzene and wheels <i>Soportes de aluminio recubiertos de polizeno y ruedas</i>	●
Max. length of horizontal cut <i>Máximo largo de corte horizontal</i>	4200 mm
Max. height of vertical cut <i>Máxima altura de corte vertical</i>	2200 mm
Max. height of horizontal cut <i>Máxima altura de corte horizontal</i>	with clamps / sin pinzas - 2080 mm without clamps / con pinzas - 2030 mm
Max depth of cut <i>Máximo grueso de corte</i>	60 mm
Scoring blade diameter <i>Diámetro de hoja incisor</i>	80 mm
Independent motor of scoring unit <i>Motor independiente del grupo incisor</i>	●
Motor output of scoring unit <i>Potencia motor grupo incisor</i>	0,25 HP

ACCESSORIES AND OPTIONALS / ACCESORIOS Y OPCIONALES

Supplementary low level stop <i>Tope suplementario</i>	○
Extra short cutting device (RH) <i>Dispositivo corte paneles pequeños suplementario</i>	○
Repetitive cutting device of horizontal strips <i>Dispositivo de cortes repetitivos de bandas horizontales</i>	○
Scoring unit with 2 H.M. Knives <i>Grupo incisor con 2 cuchillas</i>	✕
Scoring unit with split saw blade <i>Grupo incisor de doble sierra</i>	●
Electronic vertical measuring display <i>Medidor digital para posición vertical</i>	○
Electronic horizontal measuring display <i>Medidor digital para posición horizontal</i>	○
Sliding support for narrow pieces <i>Apoyo deslizable para piezas pequeñas</i>	●
Dust catcher for horizontal cuttings TRK <i>Conductor de polvo para los cortes horizontales TRK</i>	○
Adjustable thickness stop <i>Tope de profundidad</i>	○
Angle cutting device <i>Dispositivo de corte inclinado</i>	○
Kit V-grooving with adjustable thickness stop <i>Dispositivo Alu con tope de profundidad</i>	○

SVP 420
AUTOMATIC
CS-H
100% MADE IN ITALY



Electrowelded frame
Bastidor electrosoldado



Aluminum lower supports coated in polyzene with retractable rollers
Soportes inferiores de aluminio recubiertos de polizeno con ruedas retráctiles



Automatic shifting frame
Parrilla móvil automática



Automatic cut execution
Ejecución corte automático



Saw carriage sliding along two linear guides
Deslizamiento del carro a lo largo de dos guías lineales



Display touch screen for cut guide
Pantalla táctil



Clamping system
Sistema de pinzas



Scoring unit with split saw blade
Grupo incisor de doble sierra



Scoring unit with independent motor
Motor independiente por el grupo incisor



From almost 60 years of cutting experience, we introduce a new vertical panel saw that offers the possibility to trim also the panel bottom part to avoid heavy rotation operations. The special clamps are Putsch Meniconi exclusive system. The clamps are positioned at distance to allow the lifting of heavy and large panels.

A partir de la experiencia de casi 60 años en máquinas seccionadoras, se añade una nueva seccionadora vertical que ofrece la posibilidad de recortar la parte inferior de los tableros, evitando así las incómodas operaciones de rotación de los ableros para que se puedan recortar la parte inferior de los mismos. Las pinzas están colocadas a una distancia tal para permitir el levantamiento de los tableros pesados y grandes.

OVERALL SIZES AND CUTTING CAPACITY / DIMENSIONES Y CAPACIDADES DE CORTE

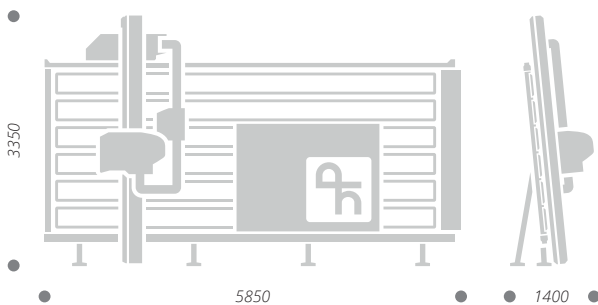

Panel saw dimensions
Dimensiones seccionadora vertical



Cutting capacity
Capacidades de corte

CUTTING MATERIALS / CORTE MATERIALES

SVP 420 AUTOMATIC CS H is designed for wood - special - plastics materials cutting.
SVP 420 AUTOMATIC CS H está diseñada para cortar madera - materiales especiales - plásticos



Wood Panels
Paneles de madera



Special Materials
Materiales especiales



Trespa®



Insulated panels
Paneles aislantes



Corian®



Plasterboard
Pladur

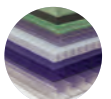

Plastic materials
Plásticos



Linear guides
Dos guías prismáticas

Sliding of saw carriage along two linear guides that allows a better precision

Deslizamiento del carro a lo largo de dos guías prismáticas

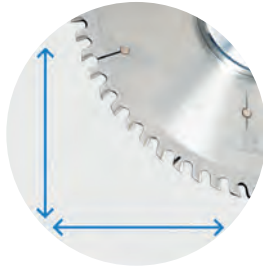

Automatic vertical horizontal cuts
Cortes automáticos verticales y horizontales

Automatic cuts program with differential speed for the return of carter on starting point

Cortes automáticos con velocidad diferencial para el corte y retorno del cabezal al punto de partida

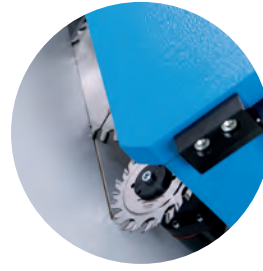

Scoring unit with split saw blade
Incisor de doble sierra

Scoring unit with double saw blade creates a pre-cutting and allows a cutting more precise and faster.

El grupo incisor de doble sierra actúa un pre-corte y permite un acabado más limpio.

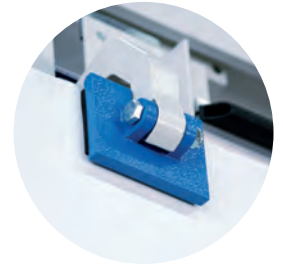

Clamping system
Sistema de pinzas

System of steady clamps, that allows the lifting of panels to make trimmings on lower parts

Sistema de pinzas, que permite el levantamiento de paneles para recortar la parte inferior de los tableros



TECHNICAL DETAILS / DATOS TECNICOS

● Standard
Standard

○ Optional
Opcional

✕ Unavailable
No disponible

TECHNICAL DETAILS *DATOS TECNICOS*

Motor output <i>Potencia del motor</i>	6 HP
Blade diameter <i>Diámetro de la hoja</i>	250 mm
Blade r.p.m. (min) <i>Rev. de la hoja</i>	5300
Shifting frame <i>Parrilla móvil</i>	electric <i>eléctrica</i>
Aluminum supports with polyzene and wheels <i>Soportes de aluminio recubiertos de polizeno y ruedas</i>	●
Max. length of horizontal cut <i>Máximo largo de corte horizontal</i>	4200 mm
Max. height of vertical cut <i>Máxima altura de corte vertical</i>	2200 mm
Max. height of horizontal cut <i>Máxima altura de corte horizontal</i>	with dampers / <i>sin pinzas</i> -2080 mm without dampers / <i>con pinzas</i> -2030 mm
Max depth of cut <i>Máximo grueso de corte</i>	60 mm
Scoring blade diameter <i>Diámetro de hoja incisor</i>	80 mm
Independent motor of scoring unit <i>Motor independiente del grupo incisor</i>	●
Motor output of scoring unit <i>Potencia motor grupo incisor</i>	0,25 HP

ACCESSORIES AND OPTIONALS *ACCESORIOS Y OPCIONALES*

Supplementary low level stop <i>Tope suplementario</i>	○
Extra short cutting device (RH) <i>Dispositivo corte paneles pequeños suplementario</i>	○
Repetitive cutting device of horizontal strips <i>Dispositivo de cortes repetitivos de bandas horizontales</i>	○
Scoring unit with 2 H.M. Knives <i>Grupo incisor con 2 cuchillas</i>	✕
Scoring unit with split saw blade <i>Grupo incisor de doble sierra</i>	●
Electronic vertical measuring display <i>Medidor digital para posición verticales</i>	○
Electronic horizontal measuring display <i>Medidor digital para posición horizontales</i>	○
Sliding support for narrow pieces <i>Apoyo deslizable para piezas pequeñas</i>	●
Dust catcher for horizontal cuttings TRK <i>Conductor de polvo para los cortes horizontales TRK</i>	○
Adjustable thickness stop <i>Tope de profundidad</i>	○
Angle cutting device <i>Dispositivo de corte inclinado</i>	○
Kit V-grooving with adjustable thickness stop <i>Dispositivo Alu con tope de profundidad</i>	○

SVP 950 MANUAL
100% MADE IN ITALY

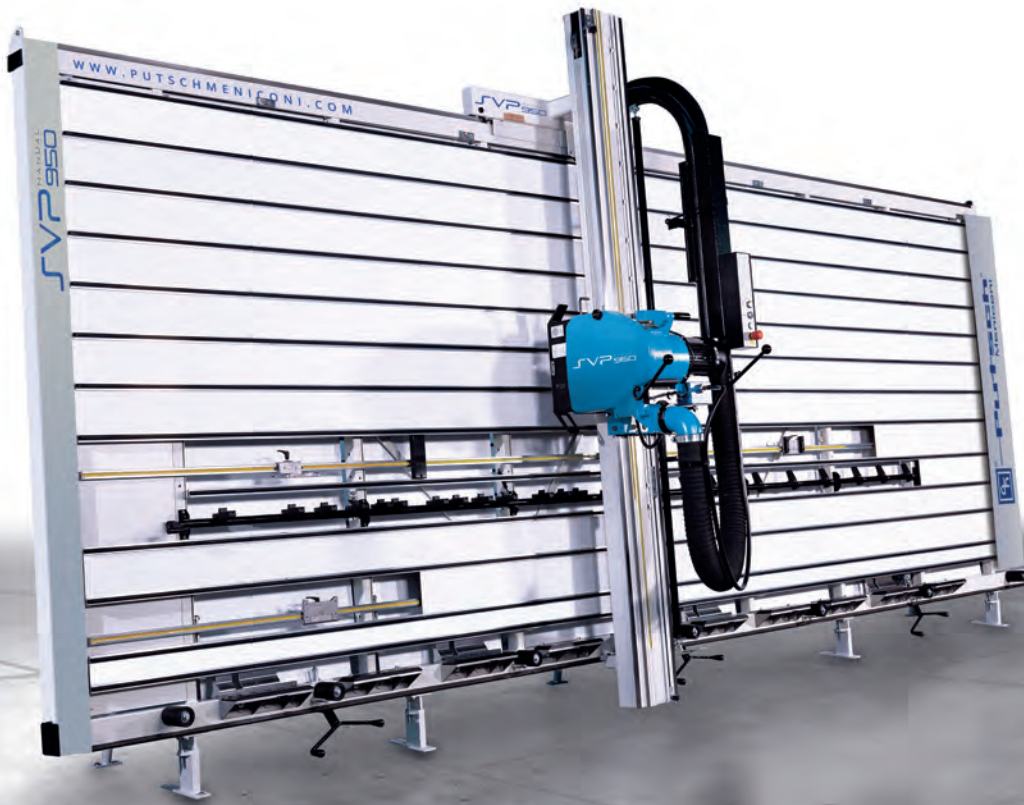

Electrowelded frame
Bastidor electrosoldado



Aluminum lower supports coated in polyzene with retractable rollers
Soportes inferiores de aluminio recubiertos de polizeno con ruedas retráctiles



Automatic shifting frame
Parrilla móvil automática



Manual cut execution
Ejecución corte manual



Scoring device with two H.M. knives
Dispositivo incisor con dos cuchillas



Depth of cut 80 mm
Profundidad de corte 80 mm



This top range model has been in the industrial market successfully for many years. It is very solid and accurate, and guarantees great performances. It is available in several configurations, even in automatic models, with a wide choice of accessories and devices to make it more versatile and practical in its applications.

Modelo de alta gama que lleva muchos años de éxito en el mercado, caracterizado por su gran solidez, máxima precisión y excelentes presentaciones. Disponible en distintas configuraciones, incluso automáticas, con una amplia gama de accesorios y dispositivos que hacen su uso más fácil y flexible.

OVERALL SIZES AND CUTTING CAPACITY / DIMENSIONES Y CAPACIDADES DE CORTE

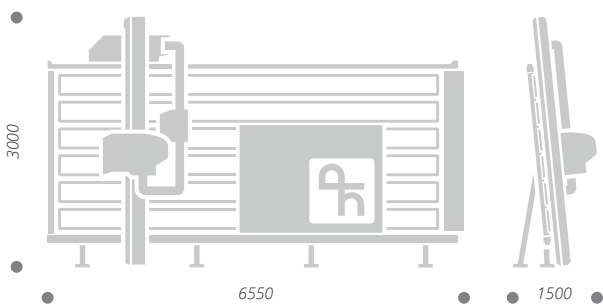

Panel saw dimensions
Dimensiones seccionadora vertical



Cutting capacity
Capacidades de corte

CUTTING MATERIALS / CORTE MATERIALES

SVP 950 MANUAL is designed for wood - special - plastics materials cutting.

SVP 950 MANUAL está diseñada para cortar madera - materiales especiales - plasticos



Wood Panels
Paneles de madera



Special Materials
Materiales especiales



Trespa®



Insulated panels
Paneles aislantes



Corian®



Plasterboard
Pladur

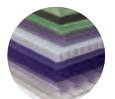

Plastic materials
Plasticos

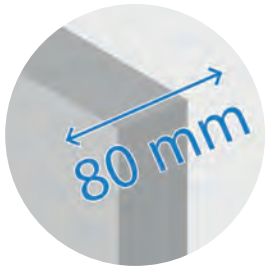

Depth of cut 80 mm
Profundidad de corte de 80 mm

Circular blade of 300mm diameter has great strength, and cutting till 80 mm depth

La sierra circular de 300 mm de diámetro tiene una gran resistencia y corte hasta 80 mm de profundidad



Motor 7,5 HP
Motor de 7,5 HP

Engine with a power of 7.5 HP which allows to work with great precision and without vibrations

Motor con una potencia de 7.5 HP que permite trabajar sin perder la máxima precisión y sin vibraciones



Automatic shifting frame
Parrilla móvil automática

Automatic shifting frame allows to avoid the cutting of plastic strips during horizontal cuts

La parrilla móvil automática permite de no dañar los listones de apoyo durante los cortes horizontales



Head mechanical plunging
Entrada mecánica de la cabeza

Mechanical system that automatically plunge the head in vertical cutting.

Sistema mecánico para ingresar automáticamente la cabeza en las operaciones de corte vertical.



TECHNICAL DETAILS / DATOS TECNICOS

● Standard / Standard ○ Optional / Opcional ✕ Unavailable / No disponible

TECHNICAL DETAILS / DATOS TECNICOS	
Motor output / Potencia del motor	7,5 HP
Blade diameter / Diámetro de la hoja	300 mm
Blade r.p.m. (min) / Rev. de la hoja	5000
Shifting frame / Parrilla móvil	electric / eléctrica
Aluminum supports with polyzene and wheels / Soportes de aluminio recubiertos de polizeno y ruedas	●
Max. length of horizontal cut / Máximo largo de corte horizontal	5300 mm
Max. height of vertical cut / Máxima altura de corte vertical	2200 mm
Max. height of horizontal cut / Máxima altura de corte horizontal	2100 mm
Max depth of cut / Máximo grueso de corte	80 mm
Scoring blade diameter / Diámetro de hoja incisor	-
Independent motor of scoring unit / Motor independiente del grupo incisor	-
Motor output of scoring unit / Potencia motor grupo incisor	-

ACCESSORIES AND OPTIONAL / ACCESORIOS Y OPCIONALES	
Supplementary low level stop / Tope suplementario	●
Extra short cutting device (RH) / Dispositivo corte paneles pequeños suplementario	●
Repetitive cutting device of horizontal strips / Dispositivo de cortes repetitivos de bandas horizontales	●
Scoring unit with 2 H.M. Knives / Grupo incisor con 2 cuchillas	○
Scoring unit with 2 split saw blades / Grupo incisor de doble sierra	✕
Electronic vertical measuring display / Medidor digital para posición vertical	○
Electronic horizontal measuring display / Medidor digital para posición horizontal	○
Sliding support for narrow pieces / Apoyo deslizable para piezas pequeñas	○
Dust catcher for horizontal cuttings TRK / Conductor de polvo para los cortes horizontales TRK	○
Adjustable thickness stop / Tope de profundidad	○
Angle cutting device / Dispositivo de corte inclinado	○
Kit V-grooving with adjustable thickness stop / Dispositivo Alu con tope de profundidad	○

SVP 950 AUTOMATIC
100% MADE IN ITALY

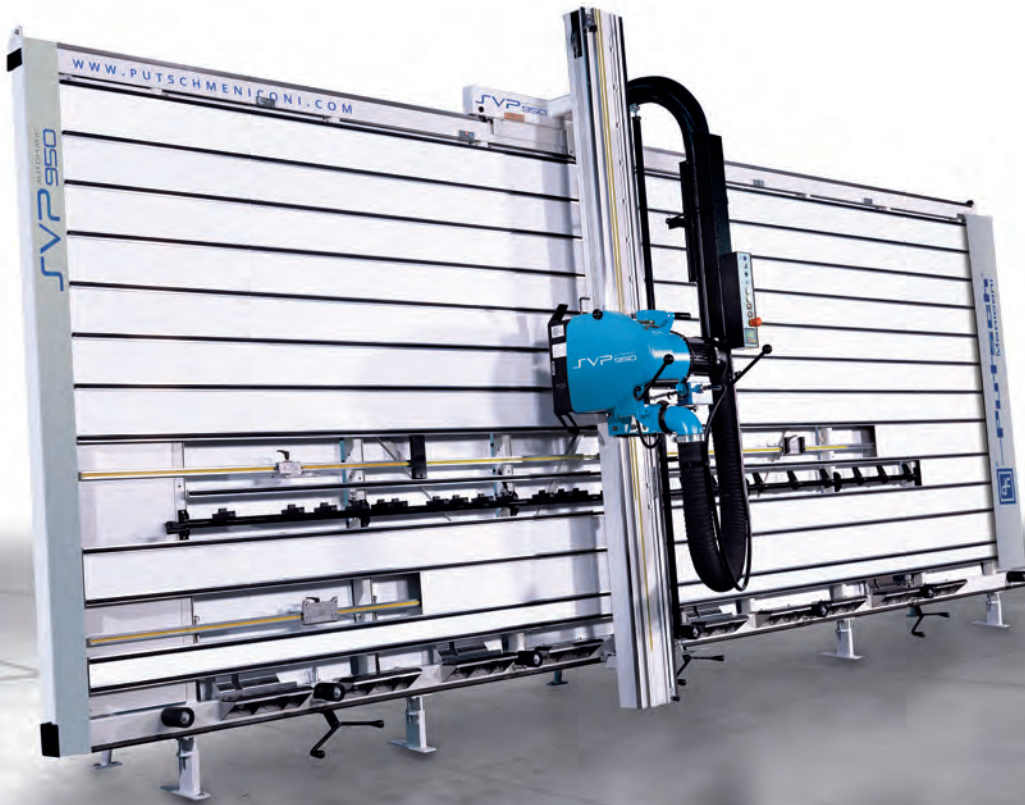

Electrowelded frame
Bastidor electrosoldado



Aluminum lower supports coated in polyzene with retractable rollers
Soportes inferiores de aluminio recubiertos de polizeno con ruedas retráctiles



Automatic shifting frame
Parrilla móvil automática



Automatic cut execution
Ejecución corte automático



Scoring device with two H.M. knives
Dispositivo incisor con dos cuchillas



Depth of cut 80 mm
Profundidad de corte 80 mm



This top range model has been in the industrial market successfully for many years. It is very solid and accurate, and guarantees great performances. It is available in several configurations, even in automatic models, with a wide choice of accessories and devices to make it more versatile and practical in its applications.

Modelo de alta gama que lleva muchos años de éxito en el mercado, caracterizado por su gran solidez, máxima precisión y excelentes presentaciones. Disponible en distintas configuraciones, incluso automáticas, con una amplia gama de accesorios y dispositivos que hacen su uso más fácil y flexible.

OVERALL SIZES AND CUTTING CAPACITY / DIMENSIONES Y CAPACIDADES DE CORTE

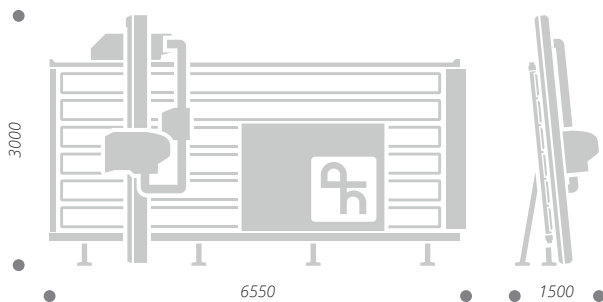

Panel saw dimensions
Dimensiones seccionadora vertical



Cutting capacity
Capacidades de corte

CUTTING MATERIALS / CORTE MATERIALES

SVP 950 AUTOMATIC is designed for wood - special - plastics materials cutting.

SVP 950 AUTOMATICA está diseñada para cortar madera - materiales especiales - plásticos



Wood Panels
Paneles de madera



Special Materials
Materiales especiales



Trespa®



Insulated panels
Paneles aislantes



Corian®



Plasterboard
Pladur

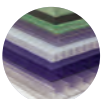

Plastic materials
Plásticos

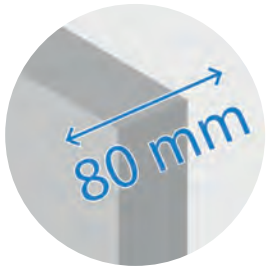

Depth of cut 80 mm
Profundidad de corte de 80 mm

Circular blade of 300mm diameter has great strength, and cutting till 80 mm depth

La sierra circular de 300 mm de diámetro tiene una gran resistencia y corte hasta 80 mm de profundidad

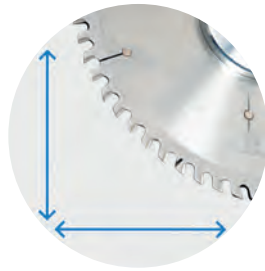

Automatic vertical horizontal cuts
Cortes automáticos verticales y horizontales

Automatic cuts program with differential speed for the return of carter on starting point

Cortes automáticos con velocidad diferencial para el corte y retorno del cabezal al punto de partida



Motor 7,5 HP
Motor de 7,5 HP

Engine with a power of 7.5 HP which allows to work with great precision and without vibrations

Motor con una potencia de 7.5 HP que permite trabajar sin perder la máxima precisión y sin vibraciones



Automatic shifting frame
Parrilla móvil automática

Automatic shifting frame allows to avoid the cutting of plastic strips during horizontal cuts

La parrilla móvil automática permite de no dañar los listones de apoyo durante los cortes horizontales



TECHNICAL DETAILS / DATOS TECNICOS

● Standard / Standard ○ Optional / Opcional ✕ Unavailable / No disponible

TECHNICAL DETAILS / DATOS TECNICOS

Motor output <i>Potencia del motor</i>	7,5 HP
Blade diameter <i>Diámetro de la hoja</i>	300 mm
Blade r.p.m. (min) <i>Rev. de la hoja</i>	5000
Shifting frame <i>Parrilla móvil</i>	electric / eléctrica
Aluminum supports with polyzene and wheels <i>Soportes de aluminio recubiertos de polizeno y ruedas</i>	●
Max. length of horizontal cut <i>Máximo largo de corte horizontal</i>	5300 mm
Max. height of vertical cut <i>Máxima altura de corte vertical</i>	2200 mm
Max. height of horizontal cut <i>Máxima altura de corte horizontal</i>	2100 mm
Max depth of cut <i>Máximo grueso de corte</i>	80 mm
Scoring blade diameter <i>Diámetro de hoja incisor</i>	-
Independent motor of scoring unit <i>Motor independiente del grupo incisor</i>	-
Motor output of scoring unit <i>Potencia motor grupo incisor</i>	-

ACCESSORIES AND OPTIONALS / ACCESORIOS Y OPCIONALES

Supplementary low level stop <i>Tope suplementario</i>	●
Extra short cutting device (RH) <i>Dispositivo corte paneles pequeños suplementario</i>	●
Repetitive cutting device of horizontal strips <i>Dispositivo de cortes repetitivos de bandas horizontales</i>	●
Scoring unit with 2 H.M. Knives <i>Grupo incisor con 2 cuchillas</i>	○
Scoring unit with split saw blade <i>Grupo incisor de doble sierra</i>	✕
Electronic vertical measuring display <i>Medidor digital para posición vertical</i>	○
Electronic horizontal measuring display <i>Medidor digital para posición horizontal</i>	○
Sliding support for narrow pieces <i>Apoyo deslizable para piezas pequeñas</i>	○
Dust catcher for horizontal cuttings TRK <i>Conductor de polvo para los cortes horizontales TRK</i>	○
Adjustable thickness stop <i>Tope de profundidad</i>	○
Angle cutting device <i>Dispositivo de corte inclinado</i>	○
Kit V-grooving with adjustable thickness stop <i>Dispositivo Alu con tope de profundidad</i>	○

SVP AUTOMATIC TOUCH
980 AT

100% MADE IN ITALY

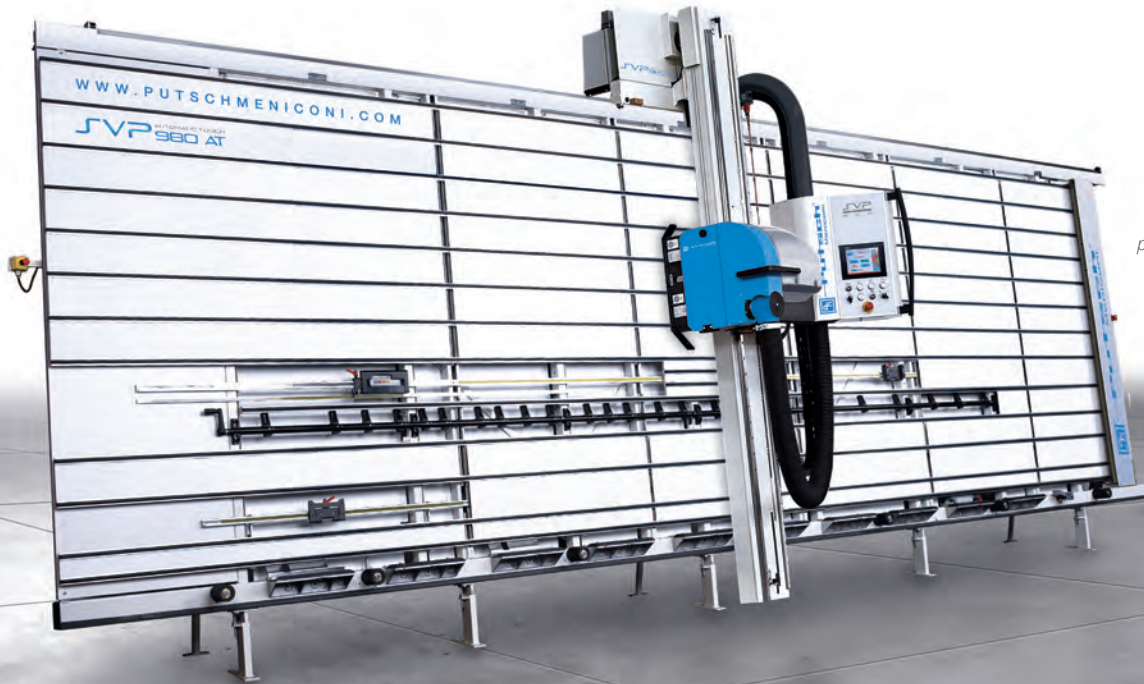

Electrowelded frame
Bastidor electrosoldado



Aluminum lower supports coated in polyzene with retractable rollers
Soportes inferiores de aluminio recubiertos de polizeno con ruedas retráctiles



Automatic shifting frame
Parrilla móvil automática



Automatic cut execution
Ejecución corte automático



Saw carriage sliding along two linear guides
Deslizamiento del carro a lo largo de dos guías lineales



Display touch screen for cut guide
Pantalla táctil



Depth of cut 80 mm
Profundidad de corte 80 mm



Scoring unit with split saw blade
Grupo incisor de doble sierra



Scoring unit with independent motor
Motor independiente por el grupo incisor



It's a new generation of machines that guarantee the utmost accuracy, thanks to the new and unique system with linear guides along the beam for carriage sliding path and on the plunging of the saw unit. Some technical innovative features like the new operating interface on board, makes this machine one of the premium vertical panel saws on the market. It also significantly increases productivity by covering the user's needs for flexibility and support when it come to advanced cutting method.

La nueva generación de máquinas que garantizan una precisión absoluta gracias también al nuevo y exclusivo sistema de guías lineales en el deslizamiento del carro y en la entrada y salida del grupo de corte. Están presentes equipamientos estandar exclusivos, únicos en su género, como la nueva interfaz operador que la pone en los mas alto nivel en el selector de las seccionadoras verticales, cojendo aquellas necesidades de flexibilidad y de soporte a el operador en el uso de la máquina, con conseqüente incremento de la productividad.

OVERALL SIZES AND CUTTING CAPACITY / DIMENSIONES Y CAPACIDADES DE CORTE

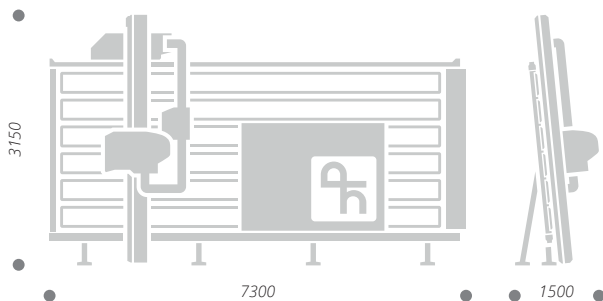

Panel saw dimensions
Dimensiones seccionadora vertical



Cutting capacity
Capacidades de corte

CUTTING MATERIALS / CORTE MATERIALES

SVP 980 AT is designed for wood - special - plastics materials cutting

SVP 980 AT está diseñada para cortar madera - materiales especiales - plasticos



Wood Panels
Paneles de madera



Special Materials
Materiales especiales



Trespa®



Insulated panels
Paneles aislantes



Corian®



Plasterboard
Pladur

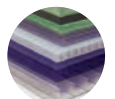

Plastic materials
Plasticos

LCD 10" touch screen with programmer for horizontal cuts LCD 10" pantalla táctil con programador de corte horizontales

PC with embedded operative system and 10" color touch screen programmer that memorizes up to 600 kinds of cutting with 40 different measures, repeatable 99 times and expandible memory.

PC con sistema operativo y pantalla táctil LCD a colores 10" con un programador de corte que memoriza hasta 600 tipos de corte con 40 medidas diferentes repetibles por 99 veces y con memoria expandible

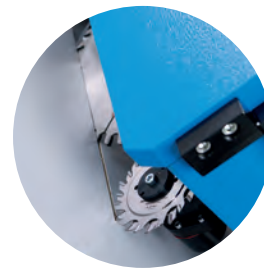

Scoring unit with split saw blade Incisor de doble sierra

Scoring unit with double saw blade creates a pre-cutting and allows a cutting more precise and faster.

El grupo incisor de doble sierra actúa un pre-corte y permite un acabado más limpio.



Linear guides Dos guías prismáticas

Sliding of saw carriage along two linear guides that allows a better precision

Deslizamiento del carro a lo largo de dos guías prismáticas

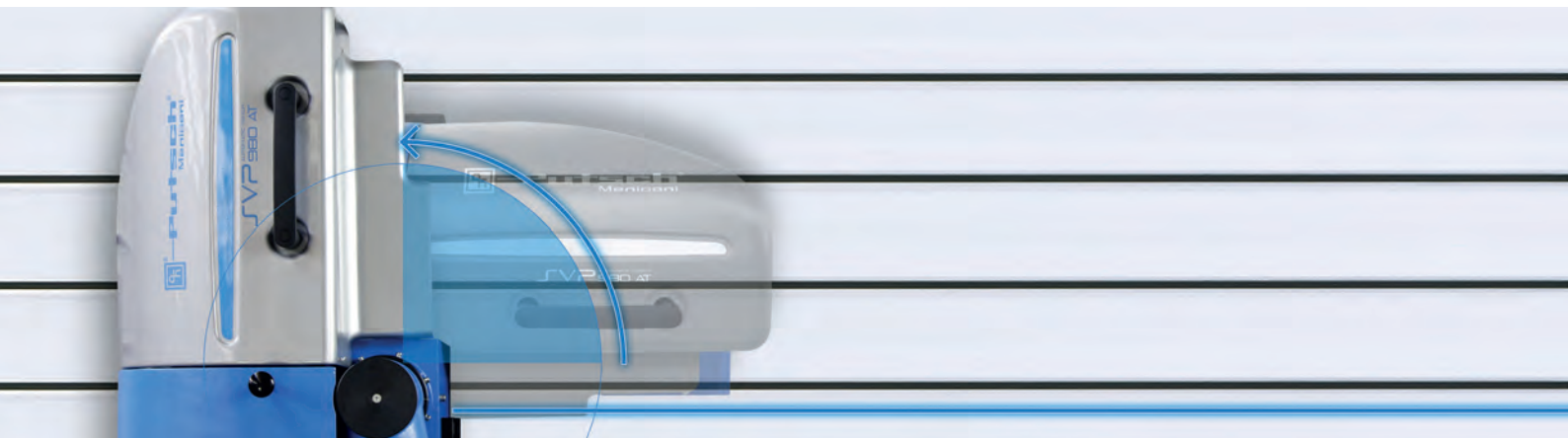

TECHNICAL DETAILS / DATOS TECNICOS

● Standard Standard ○ Optional Opcional ✕ Unavailable No disponible

TECHNICAL DETAILS DATOS TECNICOS	
Motor output Potencia del motor	7,5 HP
Blade diameter Diámetro de la hoja	300 mm
Blade r.p.m. (min) Rev. de la hoja	5000
Shifting frame Parrilla móvil	pneumatic neumática
Aluminum supports with polyzene and wheels Soportes de aluminio recubiertos de polizeno y ruedas	●
Max. length of horizontal cut Máximo largo de corte horizontal	5300 mm
Max. height of vertical cut Máxima altura de corte vertical	2200 mm
Max. height of horizontal cut Máxima altura de corte horizontal	2100 mm
Max depth of cut Máximo grueso de corte	80 mm
Scoring blade diameter Diámetro de hoja incisor	80 mm
Independent motor of scoring unit Motor independiente del grupo incisor	●
Motor output of scoring unit Potencia motor grupo incisor	0,25 HP

ACCESSORIES AND OPTIONALS ACCESORIOS Y OPCIONALES	
Supplementary low level stop Tope suplementario	●
Extra short cutting device (RH) Dispositivo corte paneles pequeños suplementario	●
Repetitive cutting device of horizontal strips Dispositivo de cortes repetitivos de bandas horizontales	●
Scoring unit with 2 H.M. Knives Grupo incisor con 2 cuchillas	✕
Scoring unit with split saw blade Grupo incisor de doble sierra	●
Electronic vertical measuring display Medidor digital para posición vertical	●
Electronic horizontal measuring display Medidor digital para posición horizontal	●
Sliding support for narrow pieces Apoyo deslizable para piezas pequeñas	●
Dust catcher for horizontal cuttings TRK Conductor de polvo para los cortes horizontales TRK	●
Adjustable thickness stop Tope de profundidad	○
Angle cutting device Dispositivo de corte inclinado	○
Kit V-grooving with adjustable thickness stop Dispositivo Alu con tope de profundidad	○

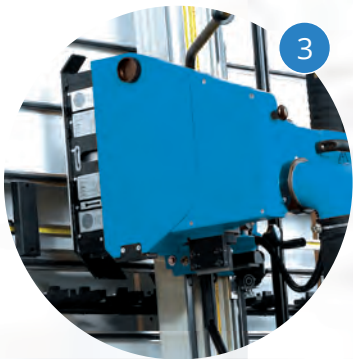
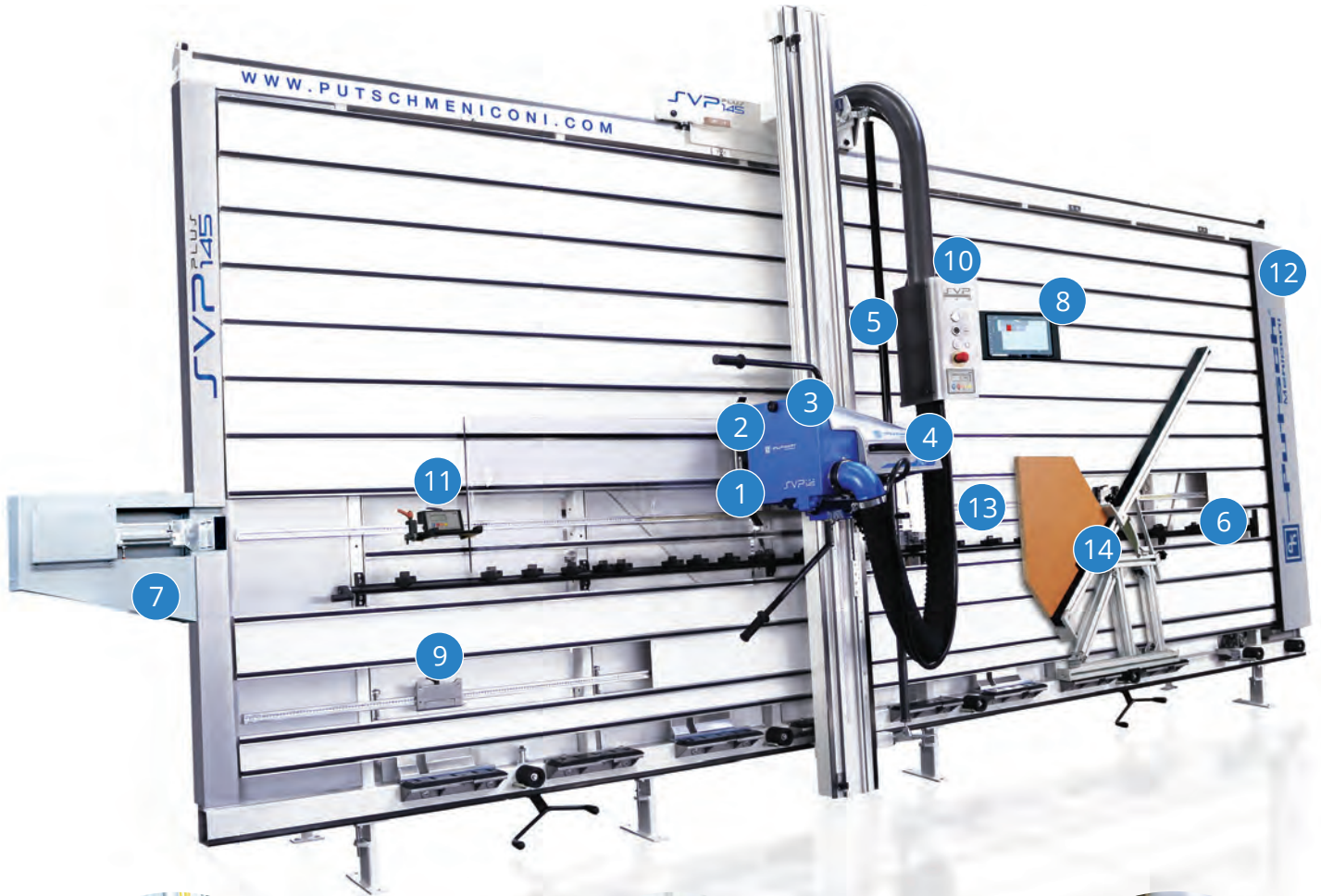

Saw head for scoring unit with split saw blades
Cabezal con incisor de doble sierra



New saw head SVP 145 plus
Nuevo cabezal SVP145 plus



Repeat cutting device of horizontal strips
Dispositivo de cortes repetitivos horizontales



Low level stop
Tope suplementario abajo



Electronic horizontal measuring display
Medidor digital para posición horizontal



Electronic vertical measuring display
Medidor digital para posición vertical

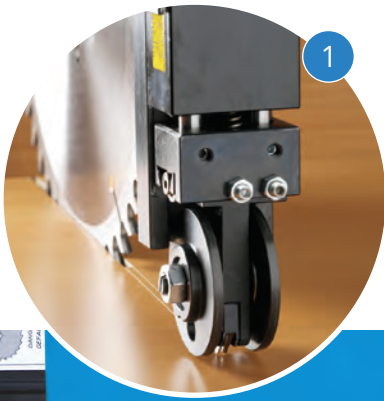

Scoring unit with 2
H.M. Knives
*Grupo incisor con dos
cuchillas*



Scoring unit with split
saw blades
*Grupo incisor de doble
sierra*

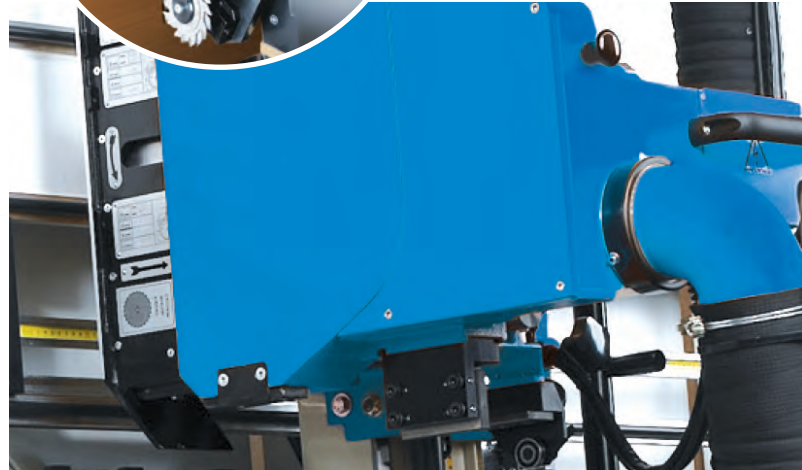
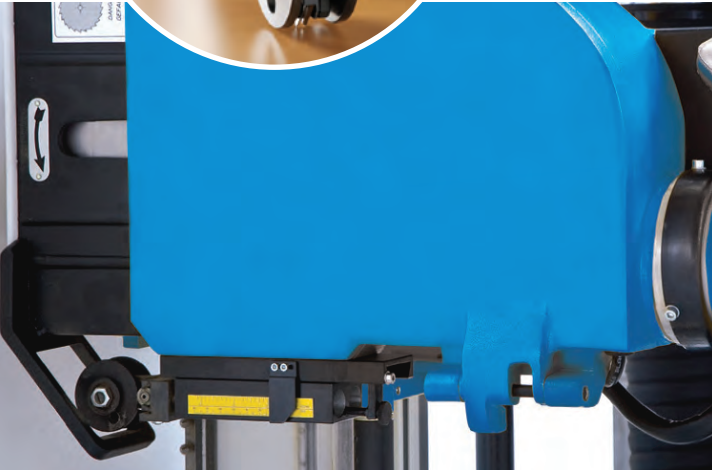

Extra short cutting device
(RH)
*Dispositivo corte paneles
pequeños suplementario*

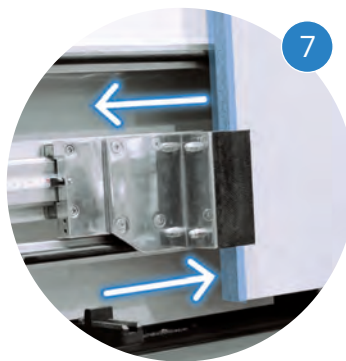

Electronic stop for vertical
cuttings Posi-System
*Tope electrónico para los
cortes verticales Posi-System*



Cut optimizer Putsch Label
on board
*Optimizador de cortes a bordo
de la maquina*



Dust catcher for horizontal
cuttings TRK
*Conductor de polvo para los
cortes horizontales TRK*



Sliding support for narrow pieces
Apoyo deslizable para piezas pequeñas



Angle cutting device
Dispositivo para corte inclinado

WALL VERSION / VERSION A PARED

Rear view of the TRK machine "wall version"

Vista trasera de la máquina TRK "version a pared"

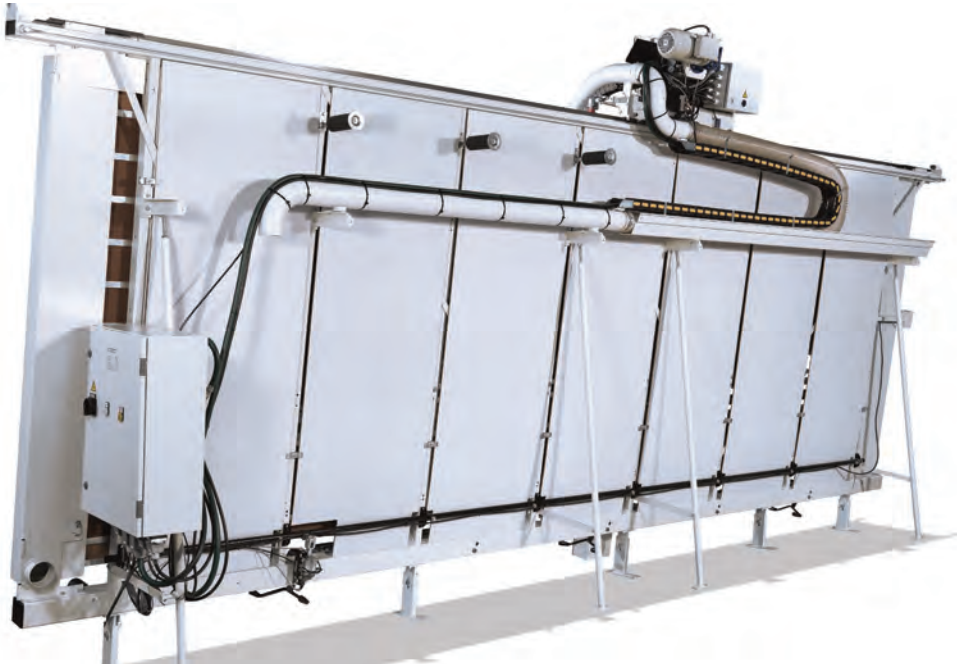

TRK / TRK

Dust catcher for horizontal cuttings, to be connected to dust collector. On request.

Conductor de polvo para los cortes horizontales para ser conectado a un extractor. Opcional.



INDEPENDENT DUST COLLECTOR
ASPIRACIÓN INDEPENDIENTE

Rear view pre-arranged for connection to an independent dust collector.

Vista trasera predispuesta para conectarse a una aspiración independiente.



DUST - EXHAUST SYSTEM
ASPIRACIÓN VIRUTAS

Integrated dust-exhaust system on models SVP 133-145; optional on SVP 950M.

Sistema de aspiración virutas incorporado en las SVP 133 - 145; opcional en la SVP 950M.



ECO SYSTEM /
SISTEMA ECO

Rear view of machine "ECO version"

Vista trasera de la máquina "version ECO"

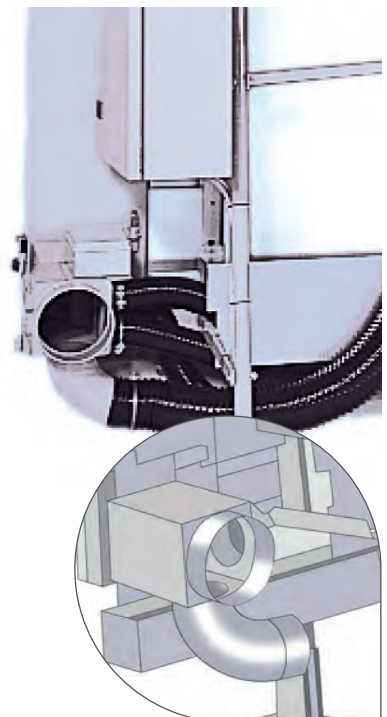



STANDARD

Standard frame with dust catcher on the head
Bastidor standard con aspiración desde el cabezal



TRK

Frame with dust catcher system TRK, that allows a better dust suction during horizontal cuttings
Bastidor con sistema de aspiración TRK, que permite la extracción de polvo durante la ejecución de cortes horizontales

ECO



ECO frame combines the TRK suction system with slats interspersed with suction nozzles that allow suction in the back for vertical cuts

El bastidor ECO combina el sistema de aspiración TRK con los canales verticales de succión que permiten la aspiración en la parte trasera durante los cortes verticales.



Special frames - Bastidores especiales

6080 - 6860 - 7640 mm

Standard
Standard

2650 mm

Special frames - Bastidores especiales

Upon request special frames with
customized cut dimensions

Bastidores especiales sobre encargo

15000 mm

3000 mm



BEAM PACKAGE / EMBALAJE BANCADA

* with scoring blade
* con incisor de doble sierra

MACHINE MAQUINA	A (cm)	B (cm)	H (cm)	WEIGHT (kg) PESO (kg)
SVP 133 BABY	290	113	75	410 / 450
SVP 133 / 133*	290 / 310	113	75 / 115	450 / 490
SVP 145 / 145*	290 / 310	113	75 / 115	460 / 500
SVP 145 ECO	290	113	115	500
SVP 145 A / ECO	310	113	115	540 / 580
SVP 320 / ECO	310	113	115	490
SVP 420 / A / ECO	310	113	115	500
SVP 420 CS H	330	113	115	650
SVP 420 A CS H	330	113	115	650
SVP 950 / ECO	310	113	115	580 / 620
SVP 950 A / ECO	310	113	115	660 / 730
SVP 980 AT / ECO	310	130	110	1060 / 1100

FRAME PACKAGE / EMBALAJE BASTIDOR

* with scoring blade
* con incisor de doble sierra

FRAMES BASTIDORES	A (cm)	B (cm)	H (cm)	WEIGHT (kg) PESO (kg)
SVP 133 BABY	407	22	170	290 / 325
SVP 133 / 133*	483	22	200	350
SVP 145 / 145*	561	22	235	450
SVP 145 ECO	561	22	235	500
SVP 145 A / ECO	561	22	235	480
SVP 320 / A / ECO	483	22	200	350
SVP 420 / A / ECO	561	22	235	500
SVP 420 CS H	563	45	270	550
SVP 420 A CS H	563	45	270	550
SVP 950 / ECO	657	25	235	535 / 590
SVP 950 A / ECO	657	25	235	535 / 590
SVP 980 AT / ECO	690	25	235	610 / 650

Technical details and pictures are only indicative. The manufacturer reserves the right to carry out modifications without prior notice.
Los datos técnicos y imágenes son indicativas. El constructor se reserva el derecho de aportar cambios sin ningún preaviso.

DISCOVER ALL PRODUCTS BY PUTSCH MENICONI DESCUBRE LA GAMA COMPLETA PUTSCH MENICONI

CNC ALLCENTER
4016
100% MADE IN ITALY

Vertical CNC working center
Centro mecanizado vertical CNC

SVP GLASS
1080
100% MADE IN ITALY

Vertical Panel Saw glass **SVP 1080**
Seccionadora vertical para vidrio SVP 1080



VANTAGE 95
100% MADE IN ITALY

Horizontal panel saws
Seccionadoras horizontales

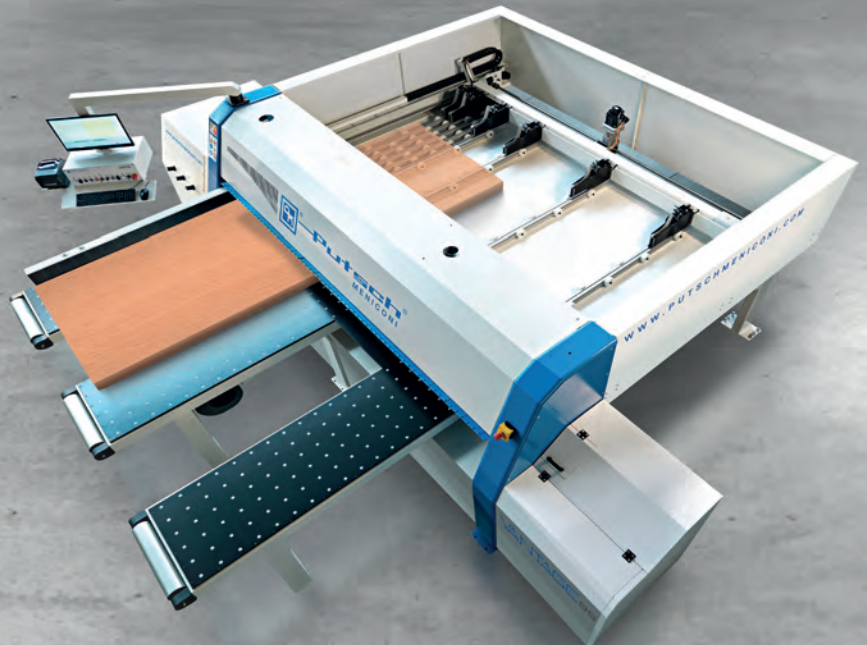

VANTAGE 95 3200

VANTAGE 95 3800

VANTAGE 95 4500



*The best way
to cut & groove*

ASSOCIATED



visit our web site



putschmeniconi.com

Putsch[®] Meniconi S.p.A.

Via Irlanda 1, 53036 POGGIBONSI (SI) Italy
Tel. +39 0577 90311 | Fax. +39 0577 979335
www.putschmeniconi.com | info@putschmeniconi.com

All rights reserved
2019
Art direction and photo
Studio Massimo Marziali S.r.l.
Printed by *Tap Grafiche S.r.l.*



facebook.com/verticalpanelsaw



instagram.com/putsch_meniconi_spa



plus.google.com/+PutschMeniconiSpa



youtube.com/user/PutschMeniconi



linkedin.com/company/putsch-meniconi